

seele health & safety manual

The seele group

The seele group, with headquarters in Gersthofen near Munich, is one of the world's top companies specialising in the design and construction of façades and complex building envelopes made from glass, steel, aluminium, membranes and other high-tech materials. The portfolio of services ranges from development and design to project management, production and complete job processing from purchasing to erection on site.

Glass treatments is another area where seele is a leader: a shear-resistant laminated safety glass for glass stairs, glass bridges and other all-glass structures is marketed exclusively by seele under the name of glascobond®.

For more information: www.seele.com



Hi, I am Oskar and I am your tourguide through our Health & Safety booklet, pointing out on some important information.

Contents

1	General remarks on safety	6
2	Personal welfare	9
3	Accidents and incidents	31
4	Logistics	36
5	Working at heights	52
6	Lifting operations.....	64
7	Hand tools	98
8	Construction machinery and equipment	108
9	Hot works.....	115
10	Environment.....	129
11	Protection of the public	135
12	Miscellaneous	143

Dear Operative

Unsafe acts and practices account for more than 90% of all construction incidents and job-related injuries.

This manual is a guide to your health and safety while you are working for seele.

The aim of the guidance in this manual is:

- *To prevent incidental injuries, occupational illnesses and damage to property*
- *To establish best uniform Health and Safety practices*
- *To familiarise all individuals with the safety practices of seele*

It is the responsibility of all individuals not only to follow these guidelines, but to contribute actively to their ongoing development and improvement. For your protection and that of your fellow workers, we request that you think, talk and act safely when undertaking every task you perform.

These working guidelines are intended for all seele employees worldwide, full-time and part-time, regular and temporary, and all other seele employment categories, i.e. contract workers, union workers, etc. They are to be considered basic guidelines, and are in no way all-encompassing. For particular country or specific site regulations please refer to the site safety plan or contact your immediate Supervisor or Site Manager.

“Safety is everyone’s business” is more than just a catchphrase for us; it means that everyone working for seele has a part to play in creating a safe workplace. A safe site will never be achieved without your participation.

Every project will have one or more procedures in place for workers to raise health, safety and environmental issues. However, please feel free to talk to any member of the seele management team at any time regarding these matters.

Please take care of yourself!

Yours faithfully
seele management team

1 General remarks on safety

1.1 General duties

seele's duties as your employer are:

- To provide a safe place of work for employees, including access to and from those places
- To provide suitable personal protective equipment (PPE) to workers
- To provide safe working procedures and to ensure that employees are told what to do
- To provide safe machinery and equipment
- To consult workers and to take action regarding any issue raised
- To ensure that employees are given the necessary training and supervision

Your duties as an installer/employee are:

- To take care of yourself and others
- To work and act safely
- To familiarise yourself with the escape routes and emergency procedures
- To not interfere with safety equipment
- To report problems and unsafe situations to your supervisor
- To report all accidents and near misses to your supervisor
- To ask your supervisor if in doubt

1.2 Personal health and hygiene

Hygiene is an important part of keeping fit and healthy and will help to prevent illness and industrial diseases.

Remember

- Always wash and dry your hands thoroughly before eating
- Always wash and dry your hands thoroughly before and after using the toilet
- Always protect yourself at work by wearing clean clothing and footwear suitable for the weather and working conditions
- Always use barrier creams on your skin before starting work in excessively dirty conditions
- Always clean and maintain all safety equipment such as hard hats, goggles, respirators/face masks and other items in contact with the skin
- Always remove material residues from your hair and skin immediately after you finish working



*Carry out your duties properly
and you will go home with a clear conscience!*

1.3 Site security

Site security is essential for the protection of all people, including the site workforce, visitors, the general public, installation materials, plant & equipment. On some building sites it may be necessary to open gates for deliveries and access or remove sections of hoarding to allow the works to progress. In some cases you may need a key to a gate to gain access during the shift.

Unauthorised persons will probably not be aware of the hazards associated with construction sites.

Remember

- Always return all keys to site security personnel and keep all gates closed
- Always keep gates locked at the ends of shifts and breaks following the individual site procedures
- Always ensure that your working area is secure

- Never leave keys in unattended machinery or equipment
- Never leave unattended gates open
- Never allow delivery vehicles to reverse without a traffic marshal
- Never allow delivery vehicles to park at off-site locations that cause a disruption to the public

2 Personal welfare

Safety is something that happens between your ears, not something you hold in your hands!

You must come to work on time, fit for duty and suitably dressed for construction work.

2.1 Personal protective equipment (PPE)

- Always wear your hard hat, safety boots, high-visibility vest and safety glasses
- Wear the correct PPE for specific tasks as identified in the following sections or refer to the risk assessment. Make sure that it fits and is worn correctly
- Ensure all your PPE is compatible
- Check your PPE each time you use it and ensure it is in date
- Damaged or expired PPE is to be reported and replaced
- Look after your PPE carefully, maintain and store it properly

2.2 Head protection

There is always a potential risk for head injuries on construction sites. Wearing the correct head protection can prevent the majority of these injuries.

Remember

- Always wear the correct PPE for the given task (e.g. hard hat, welding helmet)
 - Always inspect your hard hat to ensure it is free from defects
 - Always ensure that any attachments, e.g. welding hoods, ear defenders, face shields, chin straps, are designed and approved for the head protection you are using
 - Always use the proper safety helmet for the task (some are non-conductive or low conductivity designs, some have different ratings); consult the risk assessment
 - Always wear a hard hat with chin strap while working at heights
 - Always put on your safety helmet before entering an area where a safety helmet is required
-
- Never wear a damaged safety helmet
 - Never draw on or paint your safety helmet
 - Never remove your hard hat when in an area where a safety helmet is required

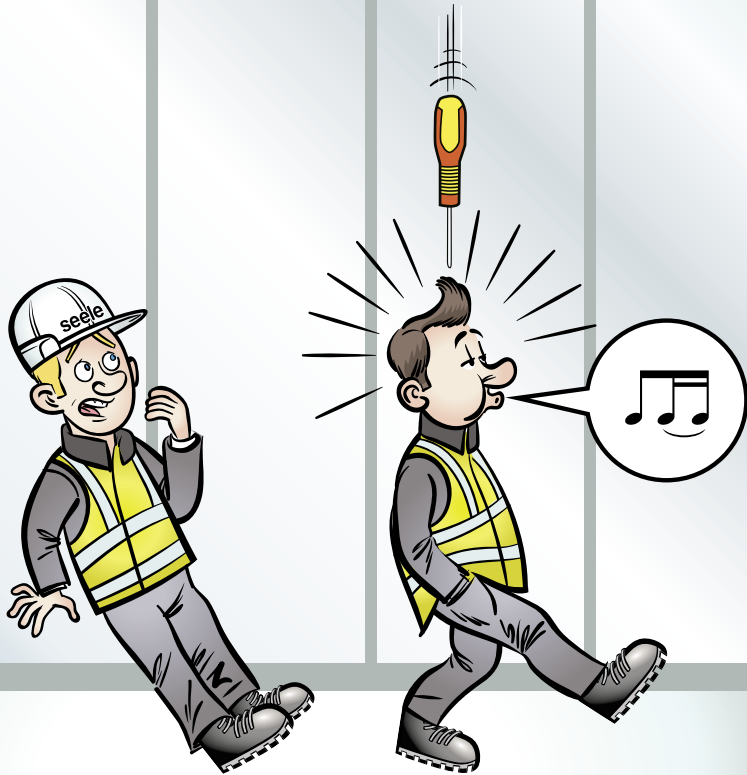



2.3 Foot protection

Proper footwear creates a solid basis for all future activities!

There are two major types of work-related foot injuries. The first type of injury includes foot injuries from puncture wounds, e.g. from protruding nails, or crushing, sprains, lacerations. The second includes those caused by slipping, tripping and falling.

Remember

- Always wear correct fitting safety footwear
 - Always ensure that safety footwear has midsoles and toe protection, and conforms to the required standard
 - Always ensure that safety footwear has ankle protection
 - Always report any damage to your footwear to your supervisor
 - Choose footwear based upon your walking surface, e.g. oil resistant, slip resistant etc.
-
- Never wear damaged safety footwear
 - Never work without safety footwear

2.4 Hand protection

You cannot work without your hands!

Hand injuries are very common in the construction industry. Injuries may include:

- Cuts, lacerations, punctures, even amputations
- Abrasions from rough surfaces
- Broken fingers or other bones of the hand
- Chemical burns
- Severe skin irritation (dermatitis) due to contact with certain chemicals
- Thermal burns from touching very hot objects
- Absorption of hazardous substances through unprotected skin

Choose the right gloves for the job.

If you think you do not have the correct type of gloves, report this to your supervisor.

Remember

Hand tools, power tools, machinery, steel, glass and other items can cause serious hand injuries.

2.5 Eye protection

Eye protection is replaceable – your eyes are not!

Remember

- Always wear eye protection where it is required and where there is a potential risk of injury
- Always use the correct eye protection for the task you are doing
- Always ensure that eye protection is comfortable to wear and keep it clean

- Never watch welding processes unless your eyes are properly protected
- Never enter areas where eye protection is required unless you are wearing suitable eye protection



*Eye protection is replaceable
– your eyes are not!*

2.6 Hearing protection

Exposure to excessive noise over long periods may lead to damage to your hearing.

The damage can include:

- Permanent hearing loss
- Your hearing becoming less sensitive
- Tinnitus (ringing, buzzing or noises in the ear)

If the noise level is such that when you are standing 2 metres (6 feet) away from a person and you have to shout to be heard, then the noise is too loud.

Remember

- Always wear the appropriate hearing protection when in a hearing protection zone or when undertaking noisy activities
- Always ensure that you wear the correct type of hearing protection; the correct PPE to be worn can be found in the following sections or the referencing risk assessment
- Always ensure that your hearing protection fits properly



2.7 Personal fall arrest equipment

Personal Fall Arrest Systems are the last resort!

Personal fall arrest equipment arrests a fall, but does not prevent it. Always attempt to remove the fall hazard first.

Always ensure that edge protection is set up when working at heights or along unprotected slab edges. Harnesses must be worn at all times where edge protection is not fitted. The length of the lanyard will depend on the distance of the potential fall.

Prior to each use, inspect your fall arrest equipment for wear, damage and other deterioration. Never use defective components.

seele

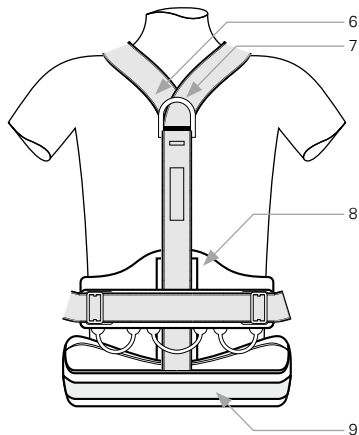
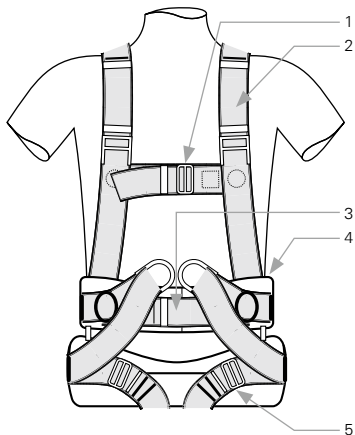

- | | | | |
|-------------------------------------|------------------------------------|-----------------------------------|-----------------------------|
| 1 Adjustable Chest Straps | 4 Abdominal Cushion Pad | 6 Elastic Shoulder Straps | 8 Cushioned Back Pad |
| 2 Adjustable Shoulder Straps | 5 Adjustable Thights Straps | 7 Attachment Dorsal D-Ring | 9 Rigid Seat Strap |
| 3 Positioning Belt | | | |

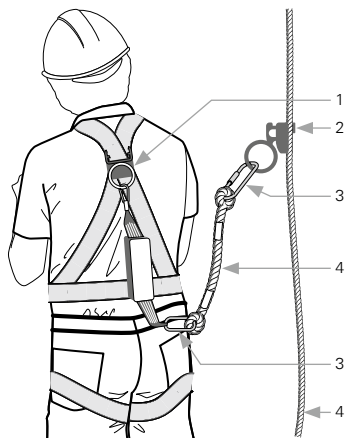

- | | |
|----------------------|-------------------------------|
| 1 Locking Strap Hook | 4 Lanyard with Shock Absorber |
| 2 Rope Grab | 5 Lifeline |
| 3 D-Clip | |

When moving from one place of work to another, the harness must be attached to a suitable safe anchorage point. For example:

- A suitable hole in the steel structure
- A safety wire specifically designed for the purpose
- A span set suspended between two anchorage points

Inertia reel: A retractable fall arrester may be provided as part of the overall system. It is essential to connect it to a secure anchorage point (normally vertically above you). For a full body harness, the attachment point must be located in the centre of your back near your shoulder or above your head. Estimation of approximate fall distance for a fall arrest system.

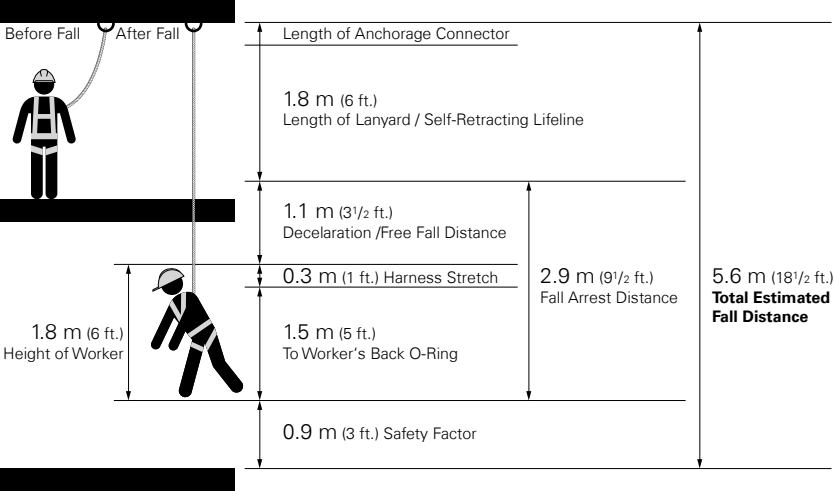

2.8 Vibration

Hand-arm vibration syndrome (HAVS) is a disorder that affects blood vessels, nerves, muscles and joints of the hands, wrists and arms. It can be severely disabling. You are at risk of HAVS if you use any vibrating equipment, e.g. hammer drills, grinders, screw guns, etc.

HAVS symptoms include:

- Tingling or numbness of the fingers
- Blanching of the fingers (whitening at the tips of the fingers)
- Loss of feeling
- Pain, tingling or numbness in hands, wrists or arms
- Loss of strength in the hands

To protect yourself from HAVS, you must:

- Report any symptoms to your supervisor
- Use the correct tools for the job
- Avoid over gripping or forcing the tool
- Reduce the amount of time you use the tool, refer to the HAVS assessment
- Keep your hands warm and wear vibration reducing gloves

2.9 Dust and respiratory hazards

Some dusts, vapors and fumes are not harmful – they might simply be a nuisance. However, others might damage your lungs and other body systems permanently. Many of these dusts and fumes are invisible and proper use of the respiratory protective equipment (RPE) selected for you and your work is essential for your health and well-being.

Checklist

- Read the information about the use and care of the RPE
- Familiarise yourself with its use and maintenance; read the manufacturer's instructions
If in doubt, consult your supervisor
- The use of Respiratory Protection requires an evaluation of workplace respiratory hazards by a Safety Professional or Industrial Hygienist
- All employees using Respiratory Protection must be properly trained in its use, care and maintenance
- All employees must be medically qualified to wear respiratory protection by a Safety of Medical Professional
- Training and Clearance must be documented
- Never enter into a hazardous atmosphere or wear level of Respiratory protection without consulting a Safety Professional first

Remember

- Always be physically fit enough to wear the RPE
 - Always use the correct type of RPE
 - Always check that your RPE fits properly
 - Always wear your RPE in hazardous areas
 - Always report any defects in the RPE to your supervisor
-
- Never remove your RPE in any hazardous area as this may contaminate the inner surfaces and expose yourselves to respiratory hazards

2.10 Exposure to UV radiation and heat

Skin cancer is one of the most common forms of cancer worldwide!

Exposure to ultraviolet radiation from the sun can cause skin damage, including sunburn, blistering skin, aging and (in the long-term) skin cancer.

While working in the sun or hot weather conditions it is important to drink plenty of water or non-alcoholic, non-caffeinated fluids in order to avoid dehydration. Alcohol and caffeine – including the caffeine in iced tea or cola – increase your potential for dehydration. The symptoms of dehydration include darker-than-usual urine or the inability to urinate, a flushed face, profuse sweating or an unusual lack of, headaches, dizziness and a general feeling of nausea. Extreme cases of dehydration can lead to heart exhaustion or even heatstroke, with the victim possibly becoming delirious or convulsive.



Skin cancer is one of the most common forms of cancer worldwide!

Remember

- Always drink plenty of water, do not allow yourself to dehydrate
- Always keep your skin covered up – wear long-sleeved shirts and long trousers
- Always apply a sunscreen to all exposed skin
- Always take your breaks in the shade
- Always check your skin regularly for unusual spots or moles. Consult your doctor without delay if you find anything that is changing in colour, itching or bleeding

A suntan is not healthy – it is a sign that your skin has been damaged!





2.11 Drugs and alcohol

Working under the influence of drugs or alcohol makes you not only a danger to yourself but to others, too. If you appear to be under the influence of drugs or alcohol, you will not be permitted to enter the site, and if found working under the influence of drugs or alcohol, you will be removed from the site.

Remember

- Always inform your supervisor if you are taking any medication that may affect your ability to work
- Always report to your supervisor if you suspect someone is under the influence of drugs or alcohol

- Never come to work under the influence of drugs or alcohol
- Never operate equipment if prescribed drugs may affect your abilities

2.12 Weil's disease (Leptospirosis)

This is a serious and sometimes fatal disease that is caused by rat urine getting into the bloodstream. Infection usually takes place via scratches or cuts in the skin or even from eating (via contaminated food), remember to always wash your hands before eating.

Symptoms

- Flu-like symptoms with a persistent and severe headache

Prevention

- Seek medical advice for all cuts, scratches and grazes
- Wash your hands thoroughly before eating, drinking or smoking
- Wear waterproof gloves when working in wet conditions
- Report any ill health to your supervisor
- Inform your doctor of your occupation if you are taken ill or suffering any of these symptoms

3 Accidents and incidents

3.1 Avoiding accidents and incidents

An **accident** is an unplanned, unwanted, unscheduled event or occurrence that may result in injury to persons or damage to property.

An **incident** is a near miss indicative of a flaw or error in the system or work process that could have caused injury or damage.

Remember

- Always ensure that you are fully competent to do the work
 - Always read and follow the method statement and risk assessment
 - Always follow the instructions given by supervisors
 - Always use the proper PPE as required by the risk assessment
 - Always use machinery and equipment as you were trained or instructed to do so
 - Always report problems to your supervisor
 - Always keep your working area tidy
 - Always inspect your workplace and equipment before you start work
 - Always plan your work in advance and plan to prevent accidents
 - Always make sure you are in a good physical condition before you start work
 - Always keep your mind on your work
-
- Never use damaged safety equipment
 - Never take chances – shortcuts can be dangerous
 - Never cut corners to get the job done quickly
 - Never use damaged machinery or equipment
 - Never repair machinery or equipment unless you are trained to do so
 - Never ignore safety signals, signs or warning devices
 - Never remove guards or barriers
 - Never play the fool on site

3.2 First aid

- Check notices giving the identity of the first aider(s) and the location of first aid equipment
- Ensure that you have the contact number(s) for the first aider(s)
- Never administer first aid if you have not been trained to do so
- Do not move an injured person unless it is absolutely necessary
- Do not douse burns with water or any other liquid
- Always report minor injuries to your supervisor

3.3 Safety inspections

Inspections do more than just help to identify potential hazards; they also show you that seele takes your health and safety very seriously. seele will arrange for professional H&S inspections to be carried out. You can help by:

- Always inspecting your workplace and equipment before you start
- Always assisting others to identify risks

- Never walk past a dangerous situation or condition without doing something about it yourself or reporting it to your supervisor/site manager
- Never concealing information or problems from the person undertaking the inspection

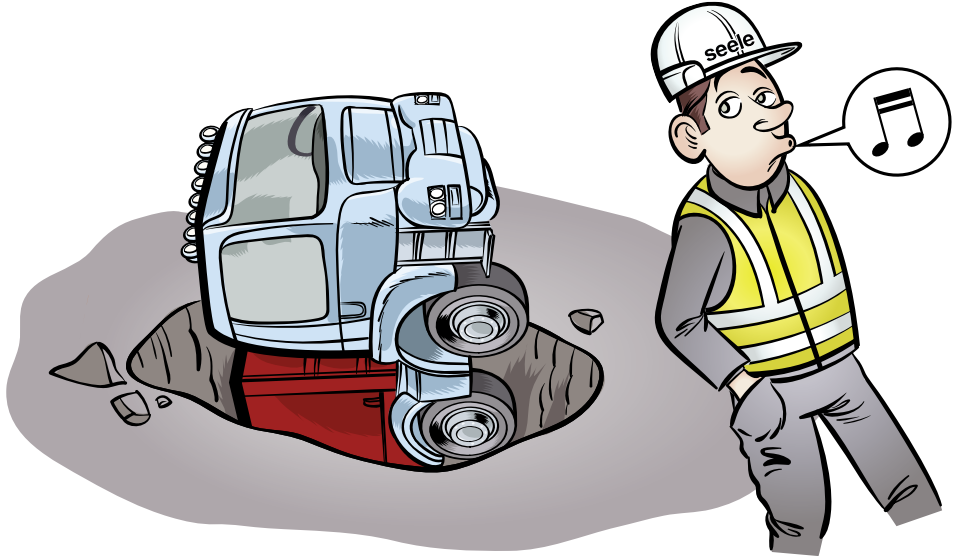

3.4 Reporting accidents and incidents

Reports about accidents and incidents allow us to establish what went wrong and help us to prevent them from happening again.

Remember

- Always report every accident or incident to your supervisor or site manager immediately
- Never allow accidents or incidents to go unreported – it may happen to someone else!

4 Logistics

4.1 Slips, trips and falls – good housekeeping

Slipping and tripping on site is not just a nuisance, it is one of the biggest causes of injury. Many of these accidents can be avoided by following simple rules. Good housekeeping is a prime concern and must be maintained at the highest level. All working areas, access routes, walkways, tool containers and lunch areas must be kept clean and tidy at all times.

Remember

- Always tidy up after yourself
 - Always keep walkways, stairways and emergency escape routes clear
 - Always remove waste and place it in the proper bins
 - Always clear up any spills immediately
 - Always route cables for power tools above head height wherever possible
If cables have to be routed at floor level, try to avoid crossing walkways
 - Always scrape mud off your boots before climbing ladders
 - Always be aware of the increased risk of tripping as the level of daylight falls
 - Always ensure that all tools, equipment and materials are stored in a safe place
-
- Never leave nails in timber
 - Never leave equipment and materials where others need to pass by
 - Never eat food other than in the designated break area



4.2 Manual handling

Correct manual handling and lifting techniques reduce the lifting effort required and prevent injuries, especially to your back.

Following these tips will reduce the effort required for lifting and the risk of injury!

- Keep your back straight
- Lift with your legs
- Keep the load close to your body

Remember

- Always use mechanical aids when available
- Always consider the route to be taken and the hazards you will encounter (e.g. uneven floor surfaces, slopes, steps, narrow passages); check that your route is clear prior to lifting the object
- Always ask for assistance when lifting awkwardly shaped or heavy loads
- Always tell your supervisor if you suffer from any pain while lifting

- Never lift more than you can handle
- Never jerk or twist the load – move your feet



4.3 Pallet trucks

- Ensure the pallet truck is suitable for the task and that its load capacity will not be exceeded
- Check the condition of the pallet truck and make sure that all wheels run freely
- Ensure the route to be used is clear, level and free from overhead obstructions
- Check that any openings/doorways are wide enough and high enough to pass through
- Be aware of the slope of any ramps along the route
- Ensure the load is correctly positioned and secured as necessary so that it cannot shift
- Ensure enough persons are available to help

4.4 Loading/unloading materials onto/from vehicles

Remember

- Always ensure that the ground is suitable for the loads being transported
- Always keep clear of passing traffic, pedestrians and other persons who are not involved in loading or unloading. A safety zone should be established to prevent unauthorised access
- Always secure the load against overturning
- Always keep clear of overhead pipes or cables so that there is no chance of fouling them or electricity jumping
- Always check the packaging of materials before lifting
- Stay clear of stored material while removing securing devices, as loads may shift or fall upon removal. Always have responsible persons remove the rigging of stored material

- Never exceed the safe working loads
- Never walk underneath or next to lifted loads
- Never walk between a fork-lift truck and an obstacle

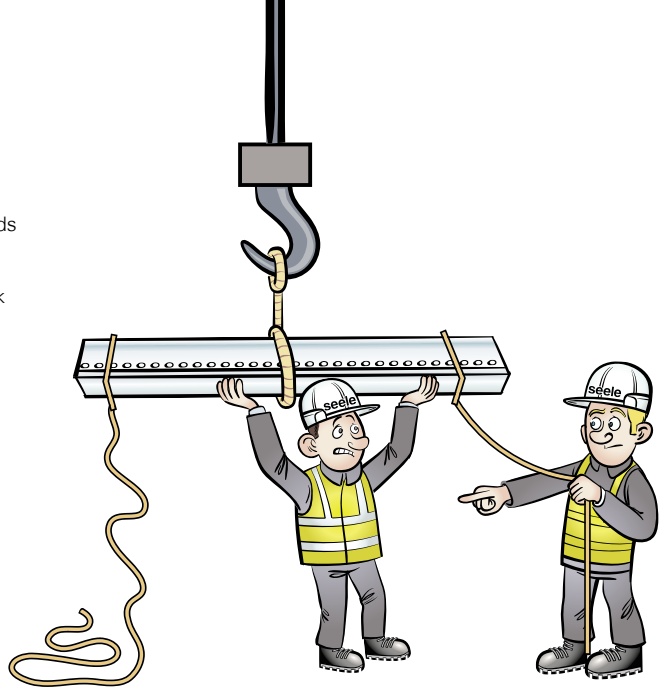

4.5 Transferring materials on site

You must remain alert when construction machinery is moving around a site. The risk of both construction workers and equipment operators being injured can be reduced if we pay attention to what we are doing. The following points will help you maintain a healthy respect for cranes, lifting gear, fork-lift trucks and vehicles:

Remember

- Always ensure that you are using the correct equipment to transport the materials
 - Always plan the route you are going to take and ensure that it is free from hazards
 - Always cordon off your working area
 - Always make sure that you are aware of other operatives working along the route
 - Always assume that the operator cannot see you or does not even know you are around
-
- Never take it for granted that other operatives can see what you are doing
 - Never attach counterweights on fork-lift trucks, mini cranes, etc. as they often create a dangerous pinch point; never get into a situation where you could get caught in such a pinch point
 - Never reverse machinery without the help of someone to check the blind spots and give signals

- Never ride on top of loaded trucks; the load might shift and you might not have enough overhead clearance in a tight spot, or you could fall under moving plant
- Never walk alongside moving plant; keep clear in case the unit suddenly turns your way, or slides, or the load shifts
- Never stand beneath loads on cranes or hoists



Always make sure that you are aware of other operatives working along the route!

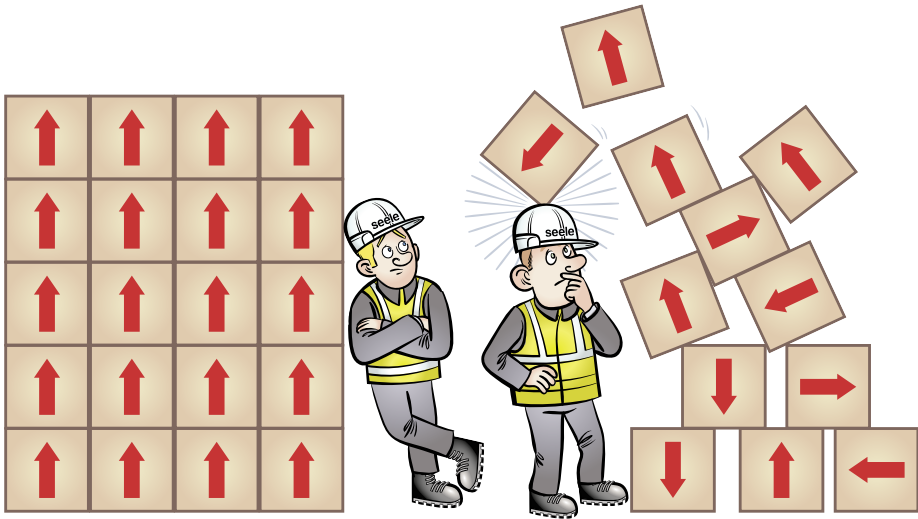

4.6 Storing materials on site

Unsafe stacking of materials can lead to serious injuries.

Remember

- Always make sure materials are only stacked/stored in designated areas
- Always stack on level surfaces
- Always leave sufficient clearance between loads for safe removal
- Always be alert to materials that might project into access routes

- Never stack or store materials near doorways, walkways or on escape routes
- Never overload working platforms
- Never stack materials in an unsafe manner

4.7 Handling glass

4.7.1 Glass – pre-delivery checks

Glass stored on building sites may present a particular hazard. Whenever possible, carry out a pre-delivery survey to ascertain where the glass is actually going to be stored and to check the following points:

- Is there enough space and access clearance to allow the delivery vehicles onto the site?
- Are floors, structures and slabs able to carry the loads of the glass?
- Have the means and methods for
 - unloading the glass,
 - transporting the glass on site, and
 - storing the glassbeen arranged and communicated to all team members?
- Are the ground conditions suitable for placing glass “A” frames, crates or pallets level, compactly, etc.?
- Are the weather conditions suitable for unloading and/or lifting the glass?

4.7.2 Manual handling of glass

Depending on the size and composition of the glass to be carried, single-handed, double-handed or – for large panes – multi-handed techniques can be employed.

Straps or slings: These are used for handling large panes of glass, with the slings passed under the bottom edge of the glass so that operators can share the weight of the load. Special care must be taken to support the tops of tall panes.

Suction pads (josters): Two or three rubber pads per frame are placed on the surface of the glass and fixed by operating a small lever. When these are used for a lengthy operation, users are recommended to release and refix them at frequent intervals. The surface of the glass must be clean and dry.

Trolleys: Trolley designs vary enormously. They should be as light as possible, easily movable and only used within their design limitations. The safe working load (SWL) of the trolley should never be exceeded in terms of weight or size.

Glass carriers: Glass carriers for moving single large panes can be based on a pair of wheels placed centrally and secured to a timber base. The glass may be supported manually or by a vertical member fitted with a set of hand suction pads.

4.7.3 Storage of glass

Glass is generally stored on edge, and whether this is the short or long edge depends on size, composition, space available, etc.

Factors to consider when storing glass on edge

The glass should not be in contact with any substance that is harder than itself, e.g. concrete, stone, ferrous metals, etc. This will minimise the risk of damage and breakage, and can be implemented by covering all supporting elements with timber, felt, rubber or plastic. Care should be taken to ensure that all nails, screws, etc. are countersunk below the surface likely to come in contact with the glass.

The angle of inclination or lean of stored glass should be at least 3° from the vertical on static racks. For transportable racks, pallets and stillages, an angle of 5° – 6° is recommended. If the angle is increased beyond 6°, it will tend to put extra load on the panes at the back of the stack and may cause breakages.

Glass stored on edge should be supported as evenly as possible over its surface area. The support should ideally equal either the total length or total width of the glass. It can take the form of flat bearers at least 50 millimetres (2 inches) wide, which may be spaced to suit the size of pane being stored.

Inadequate or uneven supporting bearers will cause the panes at the back to break due to the uneven pressure being applied.

Glass stored on edge leaning against a wall at an angle of 3° has 99.86% of its weight acting in a downward or vertical direction. It is therefore essential that the flooring be of adequate strength to support the weight of the stack, and if possible the base of the rack should aim to spread the weight over the largest possible floor area, i.e. a distributed floor loading is preferable to a concentrated loading, especially when glass is being stored on a suspended floor.

Glass should be stored in dry conditions.

4.8 Directing traffic

Only a competent person may direct traffic.

Remember

- Always wear the correct PPE, i.e. orange / high-visibility green hard hat and high-visibility clothing
 - Always ensure the vehicle's visual and audible alarms are working correctly
 - Always tell the driver the site speed limit
 - Always ensure there is good communication between you and the driver
 - Always use the correct hand signals
 - Always stop other persons from crossing the path of the vehicle, especially behind reversing vehicles
 - Always ensure that the driver wears the correct PPE when leaving the vehicle on the site
 - Always follow any existing traffic management plan and use the required permits
 - Always employ a second person as an assistant when the circumstances are unclear (tight spaces, darkness, etc.)
-
- Never position yourself behind a reversing vehicle
 - Never allow vehicles to reverse unaided
 - Never allow unauthorised persons to direct traffic

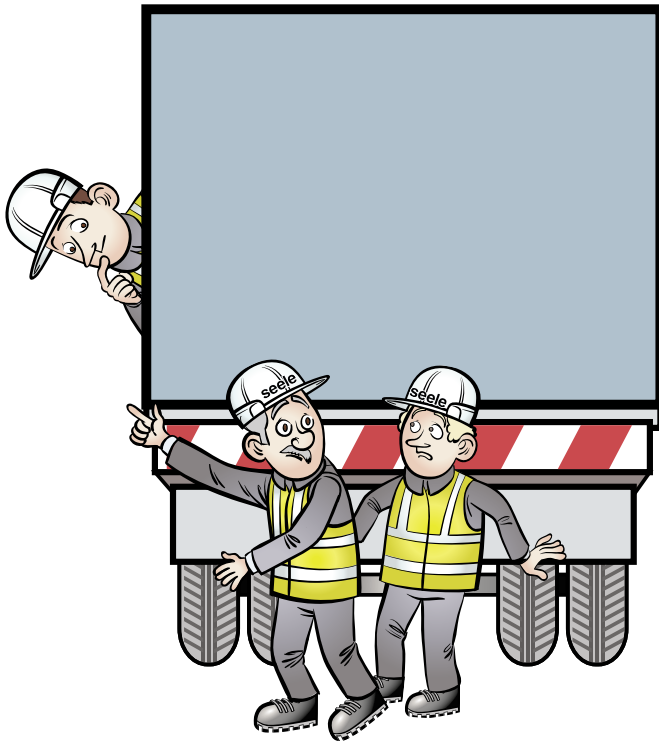

5 Working at heights

5.1 Working at heights, adjacent to openings and unguarded edges, or on roofs

Falls from heights are one of the most common causes of serious injury on construction sites and account for approx. 50% of construction deaths. Wherever possible, avoid working at heights and complete most of the work at ground level. Working at heights can be safe once a risk assessment has been completed and the safety measures are followed.

Workers must be properly trained in the specific fall protection system

Remember

- Always make sure that physical barriers protect any edge from which you could fall
- Always fit double guardrails (top rail, mid rail) and toe-boards to any working platforms in use
- Always ensure that a safe system of work with fall arrest system is in place if guardrails have to be temporarily removed, and replace them immediately after the work has been finished
- Always report any missing or damaged guardrails, toe-boards or other protection immediately
- Always use a full body harness or other approved methods for fall protection along unguarded floor edges, floor openings and other fall hazards
- Always wear the appropriate PPE with approved harnesses and equipment
- Always check your harness or restraint system for any damage each time you use it
- Always ensure the harness fits you properly

- Always ensure that the tie-off point is suitable and can carry the required load
- Always tie off to a point above your head
- Always cover all openings and penetrations with appropriate protection
- Always secure tools and materials against falling (tool tethers)

- Never work near an unprotected edge unless there are passive restraints such as nets or an approved harness or restraint system is in place
- Never leave an opening or penetration without adequate cover
- Never leave equipment for working at heights, i.e. mobile tower scaffold, in an unsafe condition
- Never cross fragile surfaces without adequate safeguards in place
- Never drag safety ropes across sharp edges
- Never climb down a safety rope

- Secure safety ropes to designated attachment points only
- Access roofs only if there is an approved fall protection system in place



Never use damaged safety equipment!

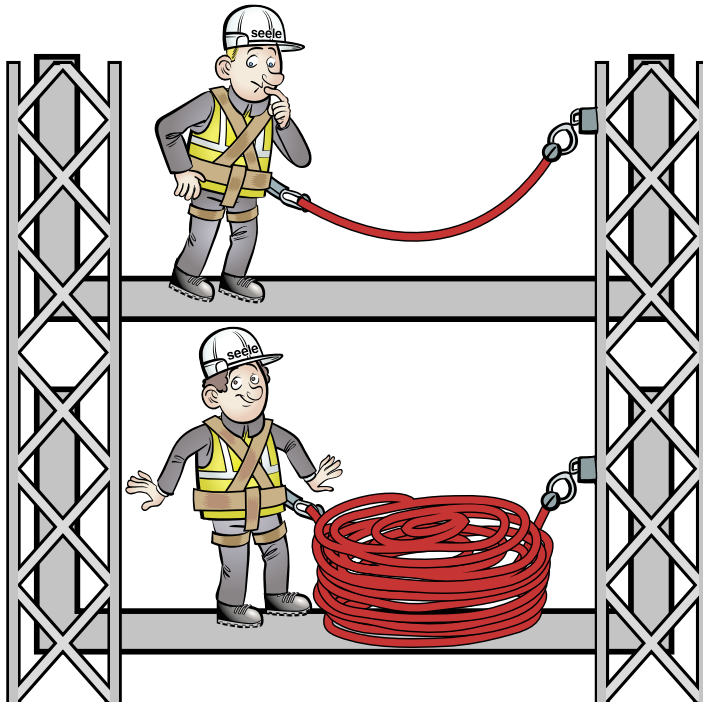

5.2 Stepladders

Stepladders should only be used when:

- The work is of short duration (less than 15 minutes)
- Only light work is involved
- Floors are complete and level

Remember

- Always choose the right location for a ladder and secure it against sinking and tilting
- Always cordon off the area around the stepladder
- Always follow the manufacturer's instructions
- Always inspect the ladder before each use

- Never use ladders with defects
- Never use a stepladder as a normal ladder, i.e. do not lean it against a wall
- Never step over onto other ladders
- Never use stepladders next to unguarded edges

- Only use stepladders with extension bars on steps/stairs

5.3 Ladders

Ladders should not be used at a place of work unless a risk assessment has been undertaken showing that there is no other safe way of doing the task.

Remember

- Always ensure the ladder is at the right angle (1:4 slope)
- Always ensure that doors/ windows have been locked when working next to them
- Always ensure the ladder is long enough for the work
- Always secure the ladder against tilting, slipping or sinking; the ground must be clean and level
- Always maintain three points of contact, i.e. two hands and a foot or two feet and a hand

- Never use a defective ladder

5.4 Podium steps

Remember

- Always check all components are available and that they function properly
- Always check that the ground is capable of supporting the weight of the podium step plus persons and equipment
- Always lock the castors when the unit is in use
- Always ensure that there are no persons, equipment or debris on the platform prior to moving it, and make sure the brake locks are off
- Always ensure guardrails and gates are locked and secure when the platform is in use
- Always take care when using power tools, high-pressure jets or other such tools that can cause a lateral force on the podium step

- Never jump onto platforms
- Never use boxes, ladders or other such means to gain additional height above the platform
- Never use podium steps on uneven surfaces
- Never exceed the safe working load (SWL) of the podium step
- Never use podium steps on mobile scaffold towers

- Only move the podium steps following the manufactures instructions

5.5 Mobile scaffold towers

Mobile scaffold towers may only be erected, altered, dismantled and inspected by trained, fully competent operatives.

Remember

- Always climb the tower on the inside, on the narrowest side
- Always work from a fully decked platform with all guardrails and toe-boards in place
- Always close the trapdoor behind you

Check that:

- Outriggers or stabilisers are correctly positioned
- Scaffoldtags are used to identify a complete or incomplete tower
- Never modify a tower unless you are trained and authorised to do so
- Never move a tower with persons, tools or materials on the platform
- Never use a tower that is incomplete or has no scaffoldtag
- Never use a ladder or hop-up to gain extra height
- Never climb on the guardrails
- Never overload a tower
- Never exceed the manufacturer's base-to-height ratio recommendations

Never move, erect or work on towers near overhead power lines! Refer to the risk assessment.

5.6 Scaffolds

Scaffolds may only be erected and modified by competent and trained persons. A scaffold tagging system (scafftags) must be introduced and maintained by a trained scaffolding operative.

Remember

- Always keep the scaffold clean and tools and materials organised at all times
- Always report defects or missing components immediately to your supervisor
- Always use the designated means of access

- Never alter or modify any scaffold for any reason
- Never climb up the standards (uprights) or cross-members
- Never work on an incomplete scaffold
- Never leave debris and materials lying around
- Never throw anything from a scaffold
- Never launch anything up a scaffold

- Only use scaffold systems that have been inspected and are considered safe to use (green scafftag)
- Only use complete scaffolds fitted with guardrails and toe-boards

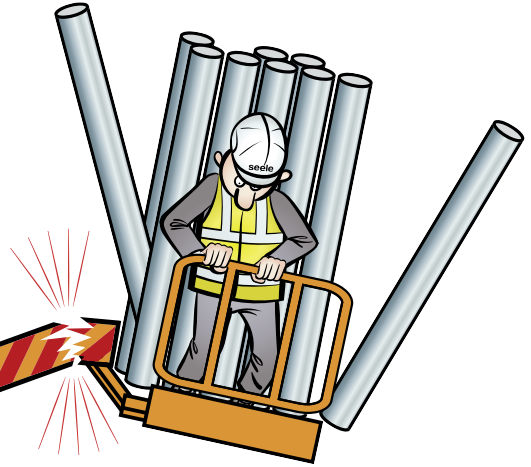

5.7 Mobile Elevating Work Platforms (MEWPs) or Aerial Work Platforms (AWPs)

Only competent, trained and qualified persons may operate MEWPs.

Remember

Always operate the MEWP in accordance with the manufacturer's instructions and any training you have received.

- Always make sure that the ground/site conditions are suitable
- Always check the MEWP for damage and defects prior to each use
- Always ensure the correct PPE is worn at all times, with particular regard to the use of harnesses. These are to be worn at all times when using a boom lift (cherry picker)
- Always remove the key to prevent unauthorised usage

- Never exceed the safe working load (SWL)
- Never lift any loads with an MEWP
- Never climb down in the event of a power failure
- Never suspend loads underneath the platform

Refer to the risk assessment if using an MEWP near overhead power cables!

5.8 Abseiling

Developments in equipment and techniques for climbing have led to new, faster and lighter ways of moving around in vertical environments. Rope access has become generally accepted as a valid way of working at heights.

Remember

- Always check your equipment for damage
 - Always make sure the anchors are secure
 - Always provide protection for the rope where it passes over on sharp or hot surfaces
 - Always fit a safety line in addition to the working line
 - Always ensure that the rope comes from the anchors and through your belay device
 - Always check that the krab attaches your harness to the belay device. Screw up the gate!
 - Always use a prusik loop or other safety device that stops you if you let go
 - Always remember that the prusik is not fail-safe, it could rub against something and release, so always try to keep hold of the control rope
-
- Never use rope access equipment unless you have a recognised training qualification
 - Never work without the safety line being attached
 - Never work alone
 - Never work without an abseiler trained to advanced level in attendance
 - Never work with damaged equipment

5.9 Walk-on nets

Walk-on net solutions, otherwise known as work positioning nets, provide an alternative form of access to other, traditional methods such as scaffolding and can be made specifically to suit the project requirements, particularly within challenging environments that involve constraints.

Remember

- Always ensure that the nets have been inspected and passed as safe to use
- Always check the safe working load (SWL) of the net before accessing it
- Always wear a harness that is secured to an anchorage point
- Always report any damage or defects directly to your manager

- Never jump into or on the nets
- Never overload the nets with either persons or materials
- Never store sharp materials or equipment on the nets
- Never remove or move any ties unless specifically trained to do so
- Never work on damaged or defective nets

- Only use a netting system for which you have been trained

6 Lifting operations

6.1 General rules for lifting operations

To prevent injuries, loads are to be lifted and transported mechanically wherever possible.

Several people with important roles are involved in lifting operations, i.e. the crane operator, the slinger/signaller and/or rigger and the lift supervisor. All of these persons must be trained and competent and follow a uniform plan.







Remember

- Always choose the appropriate lifting equipment for the specific job
- Always take into account the weights of all lifting gear/vacuum lifters in the overall load to be lifted
- Always use a appropriate spreader beam for long loads (to be determined by qualified person)
- Always check the equipment before using it; ensure that equipment has been inspected and approved
- Always ensure loads are slung correctly and secured prior to lifting them
- Always ensure the load is free to be lifted, the lifting path is unobstructed and the landing area has been cleared and prepared
- Always take into account the fact that a load being lifted might swing as it leaves the ground. Ensure the load is balanced and will not tilt or fall
- Always use taglines to control loads

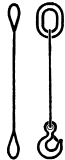
- Always adhere to the lifting instructions
- Always keep lifting equipment clean, dry and protected from corrosion

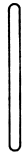
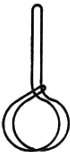
- Never attempt lifting operations unless you understand the use of the equipment and the slinging procedures
- Never allow loads to swing out of control
- Never use damaged equipment
- Never walk or stand beneath suspended loads. Warn others of this hazard
- Never leave loads suspended
- Never climb on or sit on loads being lifted! This is strictly forbidden
- Never tie loops in the ends of the taglines
- Never tie taglines around your hands or body
- Never bend, knot, twist or modify lifting equipment
Do not drag ropes across sharp edges – use appropriate protection
- Never throw, drop or drag lifting equipment
- Never repair or alter lifting equipment
- Never expose lifting equipment to chemicals, particularly acids

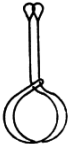
Summary of mode factors

Mode Factors								
Maximum load to be lifted = mode factor x SWL marked on the sling								
Key: NP = not preferred, NA = not applicable								
1	2	3	4	5	6	7	8	9
Material	Single leg in line	Single leg choked	Single leg basket	Single leg back hooked	Single leg halshed	Endless in line	Endless choked	Endless basket 0-90°
								
Chain	1	0.8	1.4	1	NP	NP	1	NP
Wire rope	1	0.8	1.4	1	1.6	NP	1	1.4
Webbing	1	0.8	1.4	NA	NP	1	0.8	1.4
Fibre rope	1	0.8	1.4	1	1.6	1	0.8	1.4
Round sling	NA	NA	NA	NA	NA	1	0.8	1.4

Due to the traverse pull the tensible forces are higher the wider the angle between the legs of the lifting ropes gets.

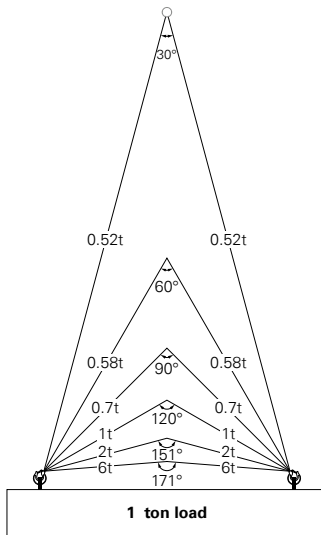

6.2 Lifting accessories – hooks and eyebolts

Remember

- Always inspect hooks and eyebolts prior to use, any items failing an inspection must be disposed of
- Always verify that the hooks and eyebolts are properly rated for the intended lift

Hooks

- Primary hooks and single-leg chains must be fitted with safety latches
- Position hooks to face outwards

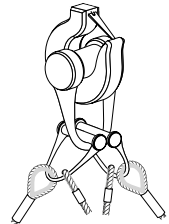

Eyebolts

- Ensure that the eyebolt and the thread of the hole are compatible and strong enough for the load
- Align the plane of the eye correctly using shims where necessary
- Ensure the collar is fully seated when hand tight
- Never apply shock loads to eyebolts
- Do not force hooks or other fittings into the eye – they must fit easily
- Never use a single eyebolt to lift a load that is free to rotate

Eyebolt Inspection Points

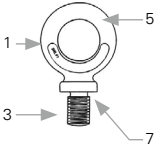
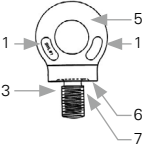
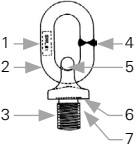

- 1** Markings illegible
- 2** Link distorted or cracked
- 3** Screw threads worn, damaged or incomplete
- 4** Weld cracked

- 5** Eye distorted
- 6** Underside of collar not flat
- 7** Shank bent

6.3 Lifting accessories – shackles

Shackles are available in a range of material grades, sizes and designs; the most common types are dee and bow shackles.

Remember

- Always inspect shackles before use and before placing into storage; any shackles failing the inspection must be disposed of
- Always select the correct pattern of shackle and pin
- Always ensure the pin is screwed correctly into the shackle eye
- Always fully tighten the pin by hand
- Always ensure the load is applied through the centre-line of the shackle

- Never use shackles with bent pins or deformed bodies
- Never force, hammer or wedge shackles into position

- Never load shackles eccentrically
- Never replace the pin with a bolt
- Never fit pins in contact with moving parts that may loosen or unscrew them (hook on pin, sling on shackle)
- Never apply shock loads to shackles
- Never alter, modify or repair shackles and never replace missing pins with unidentified pins, bolts, etc.

Shackle Inspection Points

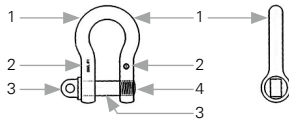

- 1 Body distorted or has visible nicks, cracks or gouges
- 2 Markings illegible
- 3 Wrong pin fitted, pin bent or of incorrect fit
- 4 Sew threads damaged or incomplete

6.4 Lifting accessories – chain and wire rope slings

Chain and wire rope slings are available in a range of material grades, sizes and forms. Select the slings to be used and plan the lift taking the following into account:

- Type of sling to be used: endless, single-, two-, three- or four-leg
- Capacity: The sling must be both long enough and strong enough for the load and the slinging method
- Apply the mode factor for the slinging method
- If it is necessary to adjust the leg length, select a sling with chain-shortening clutches
- In the case of multi-leg slings, the angle between the legs should not be less than 30° nor exceed the maximum marked
- Multi-leg slings exert a gripping force on the load which increases as the angle between the legs increases; this must be taken into account

Keep chain and wire rope slings clean and protected against corrosion. Prior to use, inspect slings and pass the sling to a competent person for thorough examination in the event of the following defects: illegible markings, distorted fittings, worn, stretched, bent or twisted links, ineffective safety catches, cuts, nicks, gouges, cracks, corrosion, heat discoloration or any other defect evident in the chain or fittings.

Remember

- Always check the correct engagement of fittings and appliances
- Always position the hooks of multi-leg slings facing outwards from the load
- Always ensure that the chain is not twisted or knotted
- Always hook free legs back to the master link to avoid loose legs that might accidentally become engaged or otherwise become a hazard
- Always take up the load steadily and avoid applying shock loads

- Never use defective slings or accessories
- Never force, hammer or wedge chain slings or fittings into position; they must fit easily
- Never lift on the point of the hook

Chain Sling Inspection Points

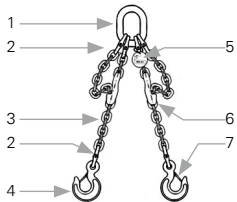

- 1** Master link distorted
- 2** Coupling components distorted or cracked or pins insecure
- 3** Chain links bent, notched, corroded, stretched or lack articulation
- 4** Hooks distorted
- 5** Markings illegible
- 6** Adjusting clutches distorted or cracked

Wire Rope Sling Inspection Points

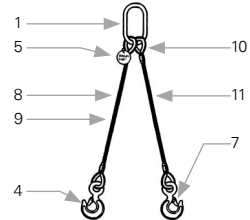

- 7** Safety catches missing or damaged
- 8** Wires cut or broken
- 9** Rope kinked or core exposed
- 10** Thimbles distorted
- 11** Signs of movement at ferrule or splice

6.5 Lifting accessories – round and webbing slings

Round and webbing slings are used for easily damaged loads and because of their lightness and ease of handling when long lengths are necessary.

However, they are susceptible to damage and must be protected from sharp edges and from sliding along the load if used at an angle. Examine the slings prior to use and ensure that their identification and specification are correct.

- Check the correct engagement with fittings and appliances, ensure smooth radii are formed;
do not twist, tie, knot or cross slings and do not overcrowd fittings
- Position the sling so that the load is uniformly spread over its width
- Ensure that stitching is in the standing part of the sling away from hooks and other fittings
- Always take up the load steadily and avoid applying shock loads
- Refer to the manufacturer's literature for colour coding and further information

Protecting the load or sling

- The sling and/or load may require protection against damage
- If the sling passes around any sharp edges or corners, suitable packing should be used to protect the sling and/or the corners of the load
- Consider the use of timber packing and slip tubes near the corners of the load

Flat Woven Webbing Sling Inspection Points

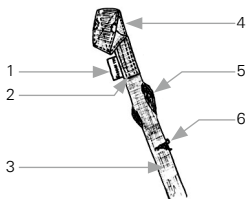

- 1 Marking illegible
- 2 Stitching damaged or loose
- 3 Heat damage including hard shiny areas due to friction
- 4 Eye or eye reinforcement damaged, chafed or cut
- 5 Webbing damaged, frayed, signs of chemical attack or solar degradation

Flat Woven Webbing Sling Inspection Points

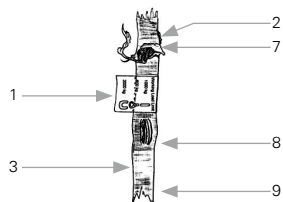

- 6 Webbing cut
- 7 Core exposed
- 8 Outer cover cur or damaged
- 9 Cover shows signs of chemical attack or solar degradation

6.6 Ratchet/lever hoist

Selecting the correct ratchet/lever hoist

Lever hoists are available in a range of capacities with either link or roller chains. Select the lever hoist to be used and plan the lift taking the following into account:

- Type of chain (link or roller)
- Capacity and range of lift

Remember

- Always inspect lever hoists and accessories before use and before placing into storage
- Always ensure any support fits easily into the seat of the hook and does not exert a side thrust on the point
- Always check the operation of the brake
- Always check that the bottom hook will reach its lowest point without running the chain against the stop

- Never expose lever hoists to chemicals, particularly acids
- Never replace the load chain with a longer one
- Never extend the lever, e.g. with a tube, or use undue effort to force the lever hoist to operate
- Never throw, drop or drag a lever hoist

- Never allow oil or grease to come into contact with the brake
- Never expose a lever hoist directly to the elements, water spray, steam, etc. without consulting the supplier
- Never use the load chain as a sling

Storing and handling lever hoists

- Never return damaged lever hoists into storage
- Never store lever hoists hung from the suspension hook with the chains raised clear of the ground. They should be dry, clean and protected against corrosion
- Never drop, throw or drag lever hoists across the floor
- Never galvanise chains
- Never subject chains to half the tensile strength
- Never shock load a chain or load bearing part

Please note that these instructions are not exhaustive and they may not be appropriate for all pieces of equipment or applications. Always refer to the manufacturer's instructions for your specific equipment. If you are still unsure, consult your supervisor.

Chain Lever Hoist Inspection Points

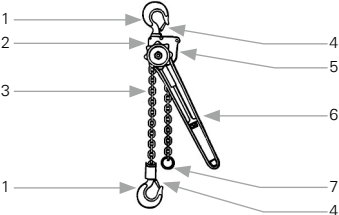

- 1** Hook distorted
- 2** Body damaged. Covers are missing/damaged
- 3** Chain is worn, links bent, notched, corroded, stretched.
Lack of articulation
- 4** Safety catch is missing/damaged
- 5** Markings illegible
- 6** Lever or control distorted
- 7** Slack end stop missing

6.7 Manual chain blocks

Selecting the correct chain block

- Manual chain blocks are designed for vertical lifting tasks only
- Take into account capacity, class of use, range of lift and type of suspension

Remember

- Always inspect the chain block and its accessories before use
- Always check the operation of the brake before making the lift
- Always ensure suspension points and anchorages are adequate for the full applied load
- Always check that the load chain/wire rope is hanging freely and is not twisted or knotted
- Always check that the bottom hook will reach its lowest point without running the chain or rope against the stop
- Always position the hook over the centre of gravity of the load

- For a top hook suspension, always use hooks that are fitted with safety catches, or mouse the hook (i.e. tie a loop in the end) and ensure the support fits easily into the seat of the hook
- For a trolley suspension, always ensure the trolley is set correctly for the beam width

- Never exceed the marked safe working load (SWL)
- Never expose chain blocks to chemicals, particularly acids

- Never replace the load chain with a longer one
- Never use the load chain or wire rope as a sling
- Never use undue effort to force the block to operate
- Never allow oil or grease to come into contact with the brake
- Never apply shock loads to the block or other equipment

Storing and handling hand- and power-operated blocks

- Never return damaged chain blocks into storage
- Store chain blocks by their top suspension, with the chains raised clear of the ground. They should be dry, clean and protected against corrosion
- Never throw, drop or drag a chain block
- Where blocks are left in situ, park the block in a suitable position so that it is protected against damage and does not constitute a danger, raise the bottom hook and isolate the unit from the power supply
- Never try to repair the chain or other loadbearing parts

Please note that these instructions are not exhaustive and they may not be appropriate for all pieces of equipment or applications. Always refer to the manufacturer's instructions for your specific equipment. If you are still unsure, consult your supervisor.

Hand chain block inspection points

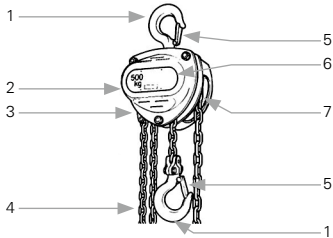

- 1** Hook distorted
- 2** Markings illegible
- 3** Slack end anchor insecure
- 4** Chain is worn, links bent, notched, corroded or stretched.
Lack of articulation
- 5** Safety catch is missing/damaged
- 6** Covers are missing/damaged
- 7** Frame distorted

6.8 Power-operated blocks

Selecting the correct block

- Power-operated blocks are designed for vertical lifting tasks only
- They are available in a range of capacities, designs and suspensions with electric or pneumatic power
- Take into account speeds (single-, dual-speed) and controls (pendant push-button, pull-cord, remote, etc.)

Remember

- Always inspect the chain block and its accessories before use
- Always ensure suspension points and anchorages are adequate for the full applied load
- Always check that the load chain/wire rope is hanging freely and is not twisted or knotted
- Always check that the bottom hook will reach its lowest point without running the chain or rope against the stop
- Always raise the load just clear then halt the lift to ensure the integrity of the block before continuing with the lift
- Always start in the slow speed if the block has more than one speed
- For a top hook suspension, always use hooks that are fitted with safety catches, or mouse the hook (i.e. tie a loop in the end) and ensure the support fits easily into the seat of the hook
- For a trolley suspension, always ensure the trolley is correctly set for the beam width

- Never exceed the marked safe working load (SWL)
- Never expose chain blocks to chemicals, particularly acids
- Never replace the load chain with a longer one
- Never use the load chain or wire rope as a sling
- Never use undue effort to force the block to operate
- Never allow oil or grease to come into contact with the brake
- Never change the direction of motion without first allowing the motor to stop

Storing and handling hand- and power-operated blocks

- Never return damaged chain blocks into storage
- Store chain blocks by their top suspension, with the chains raised clear of the ground. They should be dry, clean and protected against corrosion
- Never throw, drop or drag a chain block
- Where blocks are left in situ, park the block in a suitable position so that it is protected against damage and does not constitute a danger, raise the bottom hook and isolate the unit from the power supply
- Never try to repair the chain or other loadbearing parts

Please note that these instructions are not exhaustive and they may not be appropriate for all pieces of equipment or applications. Always refer to the manufacturer's instructions for your specific equipment. If you are still unsure, consult your supervisor.

**Power Operated
Chain Rope Block Inspection Points**

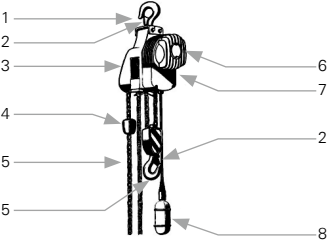

- 1 Hook distorted
- 2 Safety catch is missing/damaged
- 3 Markings illegible
- 4 Slack end anchor insecure
- 5 Chain is worn, links bent, notched, corroded or stretched. Lack of articulation

**Power Operated
Wire Block Inspection Points**

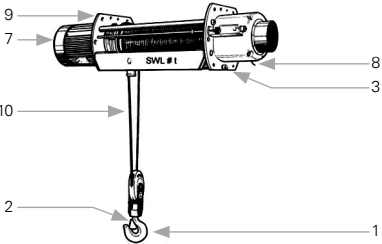

- 6 Body damaged
- 7 Covers are missing/damaged
- 8 Electrical connections insecure
- 9 Frame distorted
- 10 Wire rope is worn, has visible broken wires, kinks or corrosion. Rope falls cross over each other.

6.9 Material lifts

Material lifts are used for light, heavy and specialised lifting operations. Typically, material lifts can be moved by one person and are easy to transport from one work site to another. The following information can help you decide which material lift is right for you.

Avoid hazardous situations – know and understand the safety rules before using a material lift.

- Always perform a pre-operation inspection and function tests prior to use
- Inspect the workplace to avoid overhead obstructions or other possible hazards
- Only use the machine as it is intended to be used
- Read, understand and comply with the method statement and risk assessment
- Ensure you are properly trained to operate the machine safely

Tip-over and collision hazards

- Do not use this machine to lift people. These machines are intended for lifting materials only
- Do not stand on the platform
- Do not raise the platform unless the machine is on a firm, level surface
- Do not raise the platform unless all four legs are locked in the down position and each castor brake has been locked
- Do not raise the platform unless the load is centred and secured with ropes or straps
- Do not move the machine while the platform is raised
- Do not raise the platform in strong or gusty winds

- Do not use this machine on a moving or mobile surface or vehicle
- Lower the platform immediately if sideways deflection or bowing occurs
- Do not lower the platform unless the area below is clear of personnel and obstructions
- Do not stand beneath or allow others to pass under the machine while the load is raised
- Do not add loads while the platform is raised

Electrocution hazard

- These machines are not electrically insulated and will not provide protection from contact with or proximity to electrical currents
- Do not operate the machine within 3 metres (10 feet) of any overhead electricity supply
- Keep away from the machine if it comes into contact with energised power lines or becomes electrically charged

Improper use hazard

- Do not leave the machine unattended. Use of this machine by unauthorised personnel could result in death or serious injury

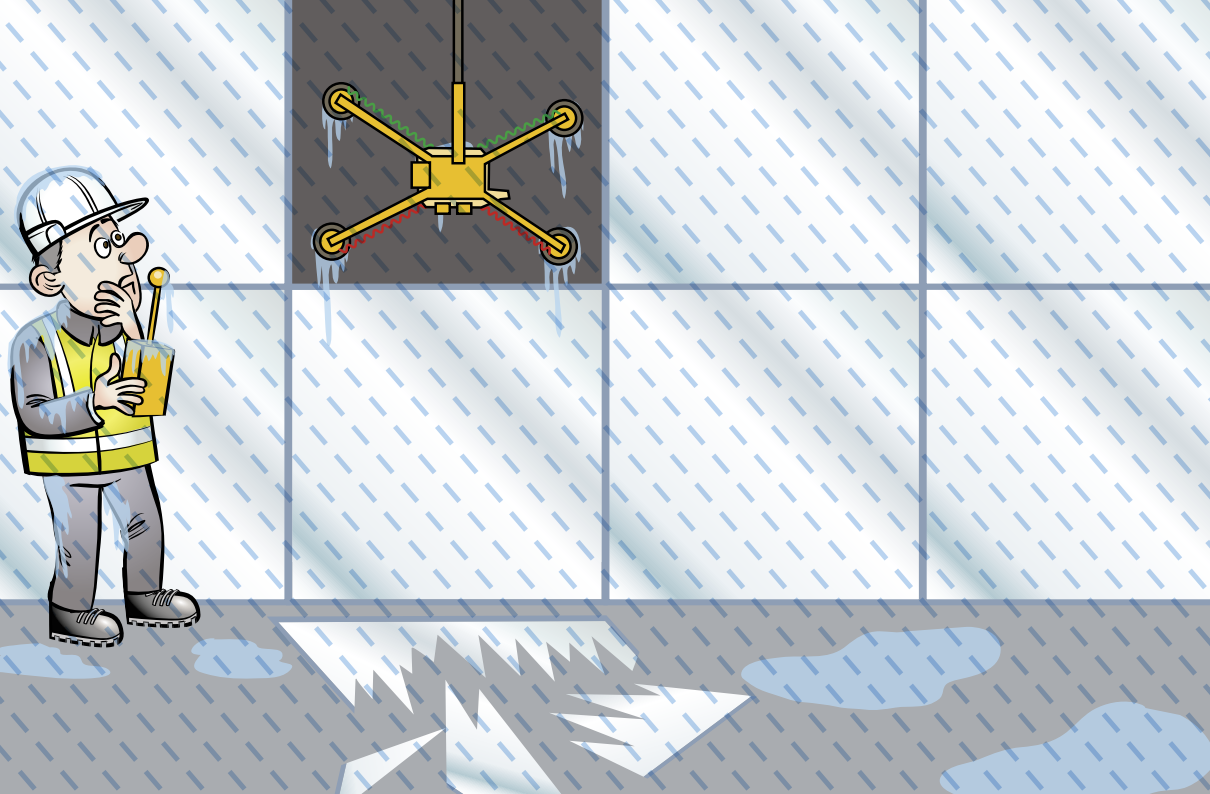

6.10 Glass vacuum lifters

Remember

- Always ensure the equipment has been inspected and has a valid examination certificate
- Always complete the vacuum lifter checklist, check the following before using the equipment:
 - Is the vacuum lifter suitable for the task regarding safe working load and glass weights?
 - Are both suction circuits working?
 - Is there any damage to the body of the vacuum lifter, suction pads or hoses?
 - Is there any damage to the lifting eye or other means of suspension?
 - Is the battery fully charged?
 - Are all suction pads connected correctly?
 - Are all suction pads clean, dry and undamaged?
 - Are all controls, warning lights and other warning devices working properly?
 - Is the glass clean and dry?

Vacuum lifter components

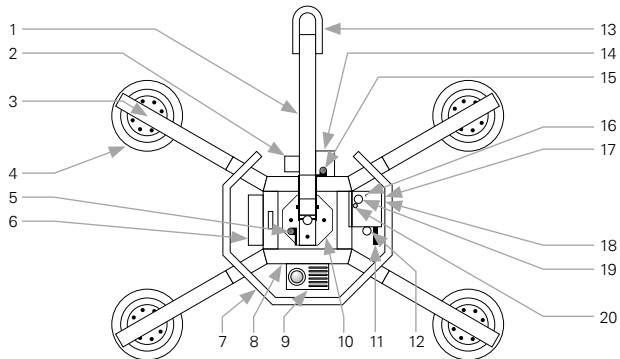

- 1 Lift Bar
- 2 Battery Charger
- 3 Extension Arms
- 4 Vacuum Pad
- 5 Rotation Release Lever

- 6 Vacuum Reserve Tank
- 7 Control Handle
- 8 Pad Frame
- 9 Vacuum Pump
- 10 Rotation Wear Plate

- 11 Valve Handle
- 12 Vacuum Gauge
- 13 Lifting Eye
- 14 Battery
- 15 Tilt Release Lever

- 16 Low Vacuum Warning Light
- 17 Vacuum Switch Enclosure
- 18 Air Filter
- 19 Battery Gauge
- 20 Battery Test Button

- Always lift the load 50 millimetres (2 inches) and wait for 30 seconds before commencing the lift in order to ensure the vacuum is stable
- Always support the load fully before applying the vacuum
- Always support the load fully before releasing the vacuum
- Always use straps to secure the glass to the vacuum lifter as an additional safety precaution for the case of a vacuum system failure
- Only use vacuum lifters if you are trained and competent to do so
- Only use vacuum lifters with two suction circuits
- Never attach to a wet pane of glass
- Never use a damaged or defective vacuum lifter



Never use a damaged or defective vacuum lifter!

Vacuum lifter pre-use inspection checklist

- Is the certificate of thorough examination valid?
- Is a user manual available for the operator's use?
- Do the serial numbers on the Report of Thorough Examination, the GGR Group test plate and the manufacturer's rating plate match up?
- Has the vacuum lifter been checked for any physical damage, particularly around welds?
- Have all vacuum pads been checked for rips, tears, quality and cleanliness?
- Are all vacuum pipes and connections secure? (Pay particular attention to quick-release fittings. Where fitted, ensure all individual pad shut-off valves are open)
- Are all electrical connections secure and all switches undamaged?
- Does the input mains voltage match the charger voltage – 110V or 240V? (circle relevant voltage)
- Does the battery have sufficient charge and does the battery charger work?
- Check the Report of Thorough Examination for the SWL of the current lifter configuration. Is it suitable for the load to be carried?
- Are rotational and tilting movements functional? Check that handles are secure during function checks
- Is the vacuum lifter energised on a non-porous surface?
- Do warning lights and audible alarms function while applying the vacuum?
- Does the vacuum reach a sufficient level before the pump switches off?
- Woods lifters only: Does the battery gauge illuminate when the pump switches off? If not, do not use!
- Pannkoke and Kappel lifters only: Does the yellow pump light remain illuminated? If not, replace 10A fuse (Pannkoke) or reset 25A circuit-breaker S2 (Kappel)
- Does the vacuum drop 5% in a 10 minute period? If so, do not use! Investigate and rectify if possible
- Where fitted, does remote vacuum application and release function correctly?

6.11 Mini crawler cranes

Construction accidents involving cranes often end in serious injuries, even fatalities. The greatest danger with crane accidents is that they can happen extremely quickly, and if the crane is carrying materials that are dropped, anything underneath them will be crushed.

Remember

- Always be aware of the slewing/swinging radius of the crane and the positions of solid objects such as walls, heavy machinery, stored materials, etc.
- Always read, understand and adhere to the lifting plan
- Always check the lifting accessories as well as the crane, e.g. chains, straps, slings, etc. prior to use
- Always inspect a mini crane prior to use
- Only use the cranes you have been trained to use
- Never carry out lifting operations without preparing a lifting plan first
- Never enter a lifting zone unless authorised to do so
- Never stand, walk or work within the slewing/swinging radius
- Never use lifting equipment that is not covered by a current certificate of thorough examination
- Never stand beneath a suspended load
- Never lift loads over other people

6.12 Mobile cranes

Construction accidents involving cranes often end in serious injuries, even fatalities. The greatest danger with crane accidents is that they can happen extremely quickly, and if the crane is carrying materials that are dropped, anything underneath them will be crushed.

Remember

- Always ensure the crane is set up in accordance with the permit stipulations and drawings
- Always be aware of the slewing/swinging radius of the crane and the positions of solid objects such as walls, heavy equipment, stored materials, etc.
- Always read, understand and adhere to the lifting plan
- Always ensure the crane driver has the necessary qualifications
- Always ensure that the crane has been inspected (certificate of safe use)
- Always check the lifting accessories as well as the crane, e.g. chains, straps, slings, etc. prior to use

- Never carry out lifting operations without preparing a lifting plan first
- Never enter a lifting zone unless authorised to do so
- Never stand, walk or work within the slewing/swinging radius
- Never use lifting equipment that is not covered by a current certificate of thorough examination
- Never stand beneath a suspended load
- Never lift loads over other people

6.13 Site tower cranes

General

The person or organisation having overall control of the place of work and the employers of personnel involved in lifting operations are responsible for safety during such operations. In order that this responsibility can be effectively discharged, the appointed person should be given the necessary authority to ensure that adequate safety systems are in place. Safety matters relating to lifting operations include the use, maintenance, repair and renewal of safety equipment and the instruction of, and allocation of responsibilities to, the various personnel in relation to the equipment.

Identification of persons directing crane movements

The person directing crane movements (slinger/rigger or signaller) should be easily identifiable to the crane operator, i.e. should wear high-visibility clothing or use radio call signs. When choosing high-visibility clothing, take into account the backgrounds, type of illumination and other relevant factors.

Proximity hazards

Consideration should be given to the presence of proximity hazards such as overhead electric cables, nearby structures, other cranes, vehicles being loaded/unloaded, stacked goods and areas to which the public has access, including highways, railways

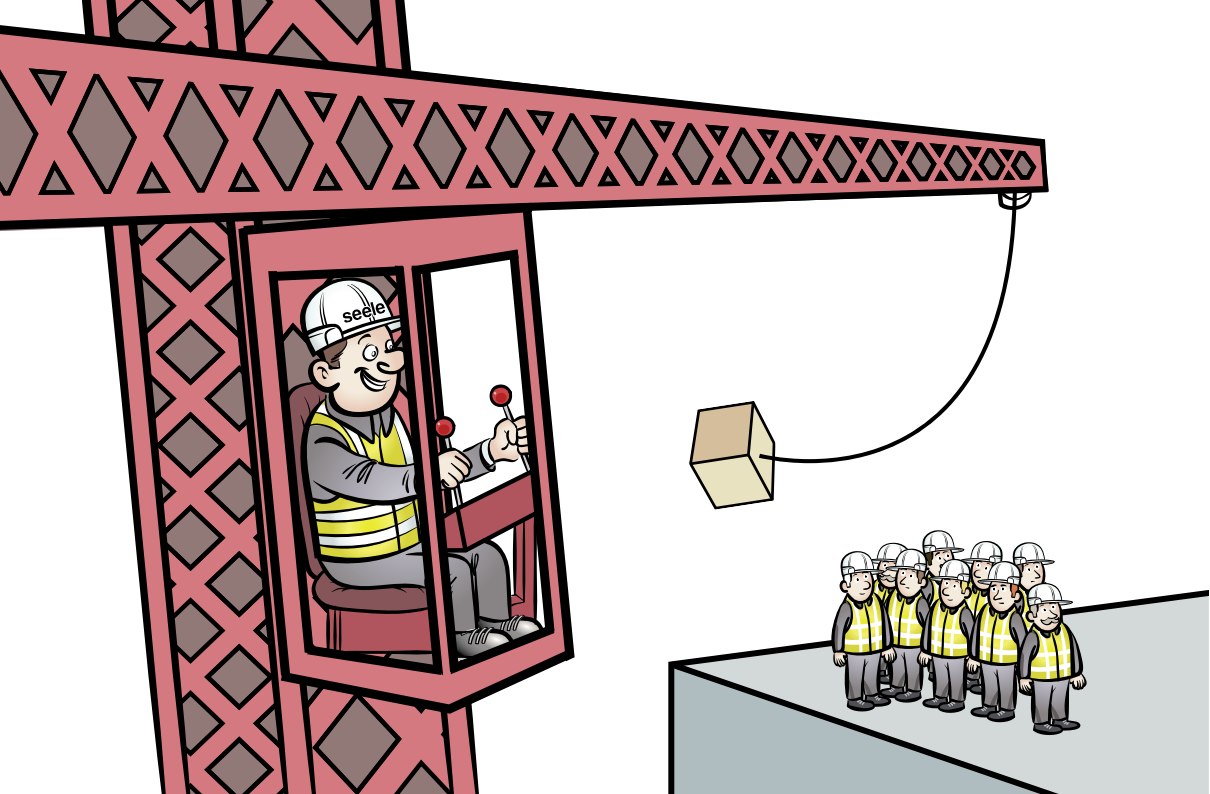

and waterways. Where any part of the crane or its load cannot be kept clear of such hazards, the appropriate authority should be consulted. The danger to or from underground services, e.g. gas pipes, electric cables, should not be overlooked when deciding where to land the load.

Handling of loads near persons

Extreme care should be exercised and adequate clearances allowed whenever loads have to be handled in the vicinity of persons. The route of the load should be planned to avoid lifting over people. Operators and signallers should pay particular attention to the possible dangers to persons working out of sight.

7 Hand tools

7.1 Use of hand tools

Using the correct tools and equipment for the task will make your job safer and more efficient.

Remember

- Always inspect tools prior to use, refer to the manufacturers' instructions
- Always handle tools with care, keep them clean and maintained
- Always store tools correctly (apply protection where appropriate, e.g. to blades)

- Never ignore safety signs or warnings
- Never use damaged or worn tools. Report any damage or faults to your supervisor
- Never carry sharp tools in your pockets
- Never force or overload tools or equipment

7.2 Working with electricity and portable electric tools

Portable electric tools can be a great help at work. But there are basic safety rules you must follow to help prevent serious injury to yourself and others whenever you are using portable electric power tools.

Only use equipment that is grounded and ensure that it has undergone portable appliance testing (PAT).

Remember

- Always assume all cables are live
- Always check the equipment visually before starting work; check power cords before each use to make sure there are no exposed wires, and that the cord is securely attached to the tool
- Always make sure that all safety guards and safety mechanisms on each of your electric tools are working properly before using them
- Always check that the power supply is suitable for your equipment; use battery-powered tools wherever possible
- Always oil moving parts as instructed by the manufacturer, and replace blades and other moving parts as needed

- Always wear safety accessories such as work gloves and goggles when working with/around power tools, and always be aware of where the power cord is so that you do not trip over it or cut it
- Always carry a portable power tool by its handle and not by the power cord
- Always unplug a tool once you have finished using it, and place it out of the way

- Only use approved equipment

- Never repair electrical equipment; it can only be repaired and tested by a competent person
- Never use damaged equipment; remove all damaged equipment from the working area and report this to your supervisor



*Never repair electrical equipment;
it can only be repaired and tested
by a competent person!*

7.3 Abrasive wheels

Remember

- Always ensure you are using the right type of wheel
- Always inspect the wheel for any defects prior to use (i.e. ring test)
- Always ensure that the spindle speed on the equipment is compatible with the rotational speed of the wheel
- Always check that the machine is secure and that all safety guards are in place
- Always wear the correct PPE, e.g. goggles
- Always be aware of noise and vibration hazards
- Always eliminate the impact of sparks => risk of fire! Do not cut near glass surfaces or people. Keep a suitable fire extinguisher nearby
- Always use both hands
- Always follow the manufacturer's instructions

- Never use abrasive wheels for side grinding
- Never use a damaged machine or damaged wheel

Please also refer to the instructions given in section 9.2 Hot works – angle grinders.

7.4 Power drills

Remember

- Always secure long hair
 - Always ensure working pieces are secured
 - Always ensure that rotational speed and drill bit diameter are compatible
 - Always use sharp drill bits suitable for the work
 - Always ensure that all parts of magnetic drilling machines are properly attached
 - Always secure the drill with a tool tether when working at heights
 - Always hold portable drills with both hands and use the auxiliary grips
 - Always disconnect the drill from the power supply prior to changing the drill bit
 - Always use the proper coolant and lubricant
 - Always follow the manufacturer's instructions
 - Always ensure that all tools are tested
 - Always check for defects prior to use
-
- Never wear rings, necklaces, watches, etc. when working with power drills
 - Never use drills on ladders – work on safe scaffolding, etc.
 - Never wear loose-fitting clothing

7.5 Use of cartridge tools

Remember

- Always ensure that personnel using cartridge-operated tools are at least 18 years of age and trained in the use of the particular tool
- Always use the equipment according to the manufacturer's instructions
- Always wear the proper PPE with the necessary eye and hearing protection
- Always consider the recoil effect associated with firing the tool
- Always consider the compatibility of the base material, the type of fixing and the cartridge strength
- Always keep anyone not involved in the activity out of the way
- Always return misfired cartridges to the stores for correct disposal

- Never point tools, loaded or unloaded, towards any person
- Never fix too close to the edge of concrete as this may cause a ricochet
- Never carry more cartridges than you need for the work you are doing
- Never use cartridge tools on ladders – work on safe scaffolding, etc.

7.6 Use of compressed-air (pneumatic) tools

The misuse of compressed air, e.g. playing with air lines, can result in serious injuries and can often be fatal, especially if the air enters the bloodstream. This behaviour is not to be tolerated.

Remember

- Always inspect hoses and fittings for signs of splits or holes
- Always ensure all pneumatic equipment is fit for the purpose, serviced and maintained in a safe condition
- Always use whip-check fittings on the hose joints
- Always wear the relevant PPE, as required by the risk assessment, e.g. eye and hearing protection
- Always ensure that the air supply is switched off when a pneumatic tool is left unattended and before being disconnected, transported or repaired
- Always release the air pressure before dismantling

- Only use the equipment within the recommended working pressures

- Never use pneumatic equipment unless you have received appropriate training
- Never kink the hose to stop the airflow – always turn the air off
- Never allow air lines to create trip hazards when laid out
- Never use compressed air for dusting down clothing or moving particulates or objects
- Never use air lines to 'blow out' residue etc.; refer to the risk assessment for other, safer methods of doing this

7.7 Use of cut-off saws and hand-held circular saws

Remember

- Always ensure the power supply is switched off before checking the saw for any damage
- Always report any damage to your supervisor
- Always check that the on/off switch works properly
- Always ensure the plug is securely fitted to the cable
- Always check that the swivel guard functions properly
- Always adjust for correct depth of cut and angle setting
- Always check the locking nuts and securing devices
- Always make sure the switch cannot be locked on. Ensure there is a grounding plug on the power cord

- Only use equipment that has been tested by a trained person

- Never wear loose-fitting clothing
- Never remove any safety guards
- Never place your hands or fingers near a running blade
- Never carry a saw by its cable

7.8 Chain-saws

Prior to using any chain-saw:

- Always ensure the appropriate safety clothing is worn, i.e. safety footwear, chain-saw gloves, eye, head and hearing protection, protective trousers and jackets
- Always make sure the saw you are using is in good working order, has been well maintained, is in a good condition and fitted with a sharp, correctly adjusted chain
- Always make sure the area in which you are cutting is free from obstacles; the nose and bar of the saw must not touch the ground or any other object
- Always make sure the saw chain is not touching anything prior to starting the engine
- Always hold the chain-saw with both hands
- Always attach the chain guard for transport
- Always ensure chain is correctly lubricated
- Always follow the manufacturer's instructions
- Always match the size of the saw and bar to the material being cut

- Never operate the saw above shoulder height
- Never operate the saw from a ladder or stepladder
- Never operate the saw when you are tired. If you get tired when using the saw, have a rest – you must be alert and in control
- Never work alone with a chain-saw – always have someone within calling distance
- Never allow other persons or animals to enter the working area while the chain-saw is in use



*Never operate the saw
above shoulder height!*

8 Construction machinery and equipment

8.1 Construction machinery and equipment – general

Remember

- Operatives of power-operated machinery and equipment must always be trained and fully competent in its use
- Operators must always check machinery and equipment before each use

- Always ensure that all safety devices are used
- Always use a banksman/flagger when reversing
- Always erect safety barriers and signs to prevent unauthorised access to the working area
- Always ensure that any warning devices, lights, etc. are functioning correctly

- Never carry passengers on machinery unless it is designed to do so
- Never leave any machinery unattended/unsecured
- Never exceed safety limitations, safe working loads, speed limits, etc.
- Never drive machinery on public highways unless it is designed to do so

8.2 Vehicle safety

The same commonsense rules apply to handling and driving company vehicles as they do when driving the family car. Read and follow the local highway code.

- Drive defensively, expect the unexpected
- Check and secure the load before you drive. Do not overload the vehicle and make sure the load is evenly distributed
- Do not reverse a vehicle without an outside banksman/flagger to watch the blind spots and warn others
- It is the driver's responsibility to:
 - check tyres, brakes, lights, horn, oil, water, fuel, etc.,
 - report any defects immediately, your life – and that of others – may be at risk,
 - keep vehicles clean and tidy and be sure they are fit to be on the road

8.3 Fork-lift vehicles

Remember

- Only operate fork-lift vehicles if you are trained, qualified and fully competent to do so

- Always carry out daily checks in accordance with the manufacturer's instructions prior to use
- Always report every defect to your supervisor
- Always adhere to the manufacturer's instructions
- Always ensure the route is free from obstacles
- Always secure the load
- Always be aware of the risk to others working nearby
- Always ensure you have a good view of the route
- Always use a banksman/flagger when reversing
- Always lower the forks as far as possible during transport
- Always keep clear of overhead electric cables
- Always ensure good ventilation when using fork-lifts indoors (exhaust fumes)
- Always ensure the charging station is situated in a well-ventilated area (electric fork-lift trucks: accumulation of explosive gases during charging)
- Always have repairs carried out by a trained person
- Always remove the key when leaving the fork-lift
- Always secure yourself in the seat

- Never transport persons on a fork-lift vehicle
- Never lift people unless a platform with guardrails has been attached to the forks.
Only vertical lifts are permitted with such platform attachments
- Never park in traffic routes or on external escape routes
- Never exceed the safe working load (SWL) of the equipment
- Never exceed the safe working loads of ground or floor slabs

8.4 Scissor and boom lifts

Please refer to the instructions in section 5.7 Working at heights – mobile elevated work platforms.

8.5 Mini crawler cranes

Please refer to the instructions in section 6.11 Lifting operations – mini crawler cranes.

8.6 Welding equipment

Please refer to the instructions in section 9 Hot works.

8.7 Glass vacuum lifters

Please refer to the instructions in section 6.10 Lifting operations – glass vacuum lifters.

8.8 Manual and power-operated chain blocks

Please refer to the instructions in sections 6.7 and 6.8 Lifting operations – manual/power-operated blocks.

8.9 Hoists and hoist towers

Lifts and hoists are used for transporting persons and goods between floors. Provided they are properly designed and maintained, there is relatively little risk to the people using them.

Construction and maintenance

- The erection, alteration or dismantling of a hoist is a specialist operation and should only be carried out by properly trained persons
- A fixed hoist tower must be adequately tied to the structure
- Hoists must be constructed in such a way that materials cannot fall from the platform or cage

Safety features

- All hoist cages and platforms must be marked with the safe working load (SWL)
- All hoists must be marked whether they are for goods or passenger use
- Passenger hoists must be fitted with interlocked gates at every landing place
- All hoists must be fitted with an efficient braking device capable of supporting the platform and load in the event of failure of the lifting gear

Operation

- Hoists should only be operated by an authorised person
- All ground level and landing gates must be kept closed while the platform or cage is in motion
- Passengers must never attempt to travel in hoists designed for goods only
- Hoists should never be used to carry loads exceeding the safe working load

Inspection

- All hoists must be subjected to periodic examination by a competent person
- Passenger hoists must be examined to test safety devices each time the height of the hoist is changed

9 Hot works

9.1 General rules for fire prevention

Preventive fire protection

- Familiarise yourself with the materials, equipment and your surroundings prior to starting work
- Access for the emergency services must be kept clear at all times
- Ensure you have proper access to the working area
- Know the fire procedures, especially the escape routes, fire points and assembly points
- Do not store flammable materials adjacent to hot works
- Keep the working area clear and unobstructed
- A work permit may be required for works involving fire hazards, e.g. welding, grinding, etc.
- Fire safety signage rules must be adhered to
- Smoking and open flames are strictly forbidden when working with highly flammable materials (refer to hot work permit)
- Keep an appropriate and inspected fire extinguisher at the workplace at all times

In case of fire:

- Fight the fire immediately if possible, but do not put yourself and others at risk!
Leave yourself a safe escape route
- Raise the alarm immediately, give details of the exact location of the fire
- Warn your colleagues
- Help persons who are in danger or call for help
- Shut doors and windows to prevent the spread of smoke/fire
- Do not use lifts/hoists, etc.
- Evacuate the area as soon as possible and proceed to the assembly point
- Re-enter the building only after being told it is safe to do so
- Used fire extinguishers must be refilled and inspected

9.2 Use of angle grinders

Important points:

- An angle grinder has an electric motor that drives an abrasive disc at high speed
- The grinder disc rotates at speeds ranging from 5,000 to 12,000 rpm
- This rotating disc is used to grind or cut metal
- The grinder size relates to the diameter of the cutting disc, which can vary. The size of grinder you should use depends on the type of job you are doing
- The smaller the grinder, the higher the rotational speed of the disc

Personal safety

Always wear protective clothing and use PPE that is appropriate for the task whenever working with an angle grinder. This may include:

- Eye protection
- Ear protection
- Hand protection
- Respiratory equipment
- If you are not sure what is appropriate or required, ask your supervisor

Safety check

- Always wear an impact-resistant full-face shield and ear protection when using an angle grinder
- Always disconnect the power supply when changing any grinding attachments or discs
- Always wear safety shoes and gloves to protect your body from flying metal chips

- Angle grinders, like all portable grinding tools, need to be fitted with safety guards to protect you from flying fragments in case the disc breaks

- Always make sure the blade guard is firmly secured, the correct type of disc has been fitted and the guard handles are secure
- Always use the correct flange or spindle nut for the type of disc being used. Otherwise the disc can shatter at high speed and injure you or others
- Always follow the manufacturer's recommendations to make sure the spindle wheel does not exceed the abrasive wheel specifications
- Always make sure there are no obvious defects or damage to the disc before you fit it

- Everyone who uses an angle grinder must receive training and instruction in safe working procedures.
- If you are unsure about anything, ask your supervisor



9.3 Welding and gas cutting

9.3.1 Welding and gas cutting – general

Welding works may only be carried out by persons trained and qualified for the specific task. Appropriate PPE is to be used (e.g. face shield, long-sleeved clothing) and the agreed welding procedures must be followed.

Remember

- Always wear protective clothing, including insulating safety boots, eye and face protection
- Always ensure that qualified support employees are nearby but outside the working area to administer first aid and switch off the supply
- Always check the equipment for damage. Report all defects to your supervisor
- Always keep your head clear of fumes, sparks, etc.
- Always ventilate the area, or use breathing apparatus
- Always read the Material Safety Data Sheets (MSDSs) and the manufacturer's instructions for the materials and equipment being used
- Always watch out for fire; keep fire extinguishers within reach
- Always protect hot metal from being touched by others
- Always keep your head and body as far away as possible from the equipment in the welding circuit
- Always work in a safe location away from other people
- Always secure the workpiece – do not hold it in your hand
- Always consider other combustible materials in the working area

- Always ventilate spaces where vapours could accumulate
- Always use guards or covers to prevent hot particles passing through openings in floors and walls
- Always maintain a continuous fire watch during the period of the work, and for at least an hour afterwards

- Never work in locations where your freedom of movement is restricted or you are forced to work in a cramped position (kneeling or sitting) or in contact with conductive parts
- Never perform welding in wet, damp or humid conditions that reduce the skin resistance of the body and insulating properties of accessories
- Never look directly at the heat source during welding operations
- Never weld near flammable materials
- Never touch hot metal
- Never work next to, sit or lean on the welding power source
- Never weld while carrying the welding power source or wire feeder
- Never wear jewellery (especially rings) or metal watch straps when welding

9.3.2 Arc welding

In addition to the general information given in section 9.3.1, the following precautions will also help to prevent injury. As the principal danger with arc welding is an electric shock from the live parts of the welding circuit (electrode and workpiece), the following practices are recommended:

Remember

- Always check that all external connections are clean and tight – daily and after each reconnection
- Always ensure the electrode holder is isolated when changing an MMA electrode
- Always ensure that an MMA electrode holder is not placed on the face shield or flammable material when welding is interrupted briefly as it may still be 'live' at 80 volts or hot enough to cause damage
- Always stand or kneel on a mat of insulating material, which should be kept dry
- Always place the welding power source outside the working area. Welding equipment needs to be grounded
- Two or more welders (with separate power sources) working on the same workpiece should always work out of reach of each other
- Only use fully insulated electrode holders
- When welding outdoors, always check that the power source protection rating is adequate for the location, do not weld in the rain without a suitable cover and ensure the welding equipment is properly grounded
- Never work in areas that are fully or partly restricted by conductive elements with which the welder is likely to come into contact accidentally

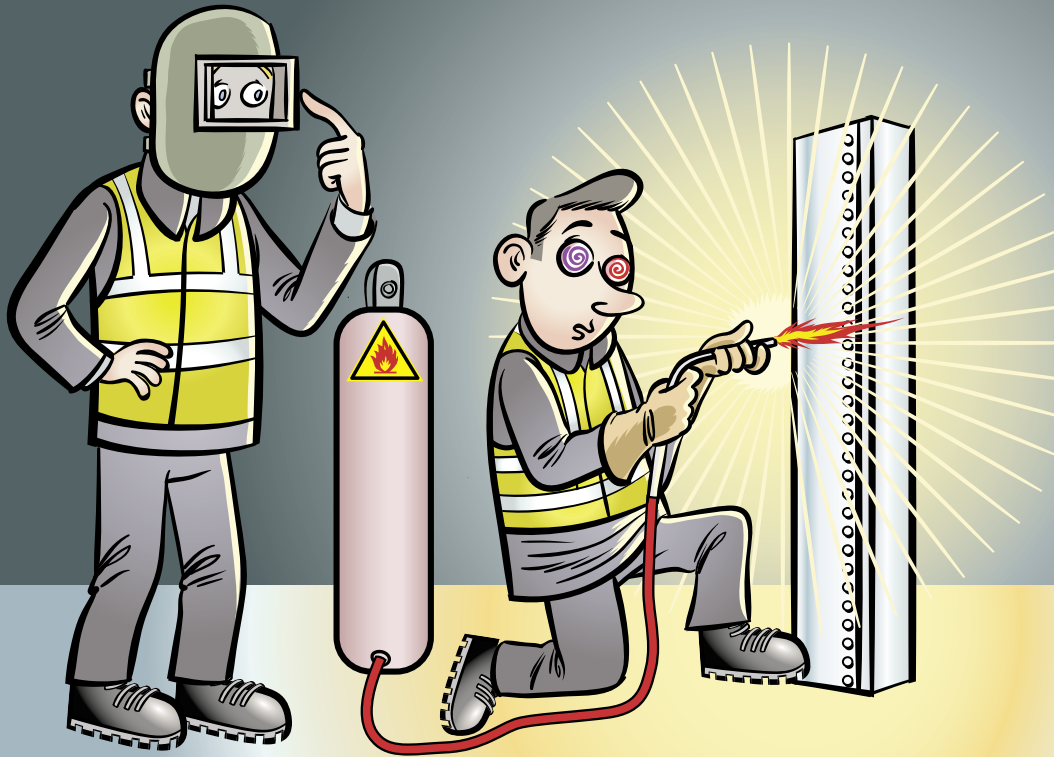

9.3.3 TIG/MIG welding

In addition to the general information given in section 9.3.1, the following precautions will also help to prevent injury:

Remember

- Always wear dry insulating gloves
 - Always insulate yourself from the work and the ground
 - Always repair or replace worn, damaged or cracked gun or cable insulation
 - Always turn off the welding power source before changing the contact tip or gun parts
 - Always keep all covers and handles securely in place
 - Always shut off the shielding gas supply when not in use
 - Always allow the gun to cool before touching it
 - Always keep cables close together by twisting or taping them, or by using a cable cover
 - Always connect work clamps to the work-piece as close as possible to the weld; always ensure that welding equipment is properly grounded
-
- Never touch live electrodes or electrical parts
 - Never weld in closed containers
 - Never place your body between welding cables. Arrange cables to one side and away from the operator
 - Never coil or drape cables around your body

9.3.4 Gas cutting

In addition to the general information given in section 9.3.1, the following precautions will also help to prevent injury:

- Always use flashback arrestors to prevent flames from travelling back up the pipes
- Shut off the blowpipe when not in use. Do not leave a lighted blowpipe on a bench or the floor as the force of the flame may cause it to move
- Keep hoses away from the working area in order to prevent contact with flames, heat, sparks or hot spatter

9.4 Highly flammable liquids (HFLs)

Remember

- Always keep flammable liquids in closed containers stored in suitable cabinets or bins of fire-resisting construction that are designed to retain spills
- Always store HFLs in designated areas that are, where possible, away from the immediate processing area, and never jeopardise the means of escape from the working area
- Always store HFLs separately from other dangerous substances that may enhance the risk of fire or compromise the integrity of the container or cabinet/bin, e.g. energetic substances, oxidising agents, corrosive materials

- Never leave HFL containers open
- Never use HFLs near sources of ignition
- Never smoke when using HFLs
- Never use more liquid than is necessary for the task in hand

9.5 Compressed-gas cylinders

Remember

- Always use gas cylinders in a vertical position unless they are specifically designed to be used otherwise
- Always restrain cylinders securely to prevent them falling over
- Always double-check that the cylinder and the gas are the right ones for the intended use
- Always wear suitable safety shoes and any other recommended personal protective equipment when handling gas cylinders
- Always close the cylinder valve and replace covers (where provided) when a gas cylinder is not in use
- Always ensure that flashback arrestors are fitted
- Always ensure that the valve is protected by a valve cap or collar or that the valve has been designed to withstand impact if the cylinder is dropped
- Always store gas cylinders away from sources of ignition and other flammable materials. Cylinders must also be stored in protective cages and clearly labelled
- Always store cylinders of flammable gas a minimum of 3 metres (10 feet; this figure must be increased to 20 feet in the USA) away from oxygen cylinders

- Before connecting a gas cylinder to equipment or pipework, always make sure that the regulator and pipework are suitable for the type of gas and pressure being used and that they are securely tightened
- Never use gas cylinders for any other purpose than for the transport and storage of gas
- Never drop, roll or drag gas cylinders
- Never lift gas cylinders by the metal cowl/collar
- Never use valves, shrouds and caps for lifting cylinders unless they have been designed and manufactured for this purpose
- Never raise or lower gas cylinders on the forks of fork-lift trucks unless adequate precautions are taken to prevent them from falling



Never drop, roll or drag gas cylinders!

10 Environment

10.1 Environmental policy

seele recognises its responsibility towards its clients, employees and the community at large and devotes considerable attention to the treatment and disposal of any hazardous and toxic materials in use in order to avoid environmental problems.

Wherever practical , seele utilises materials and products that originate from sources that are sustainable, reusable or can be recycled and are established as environmentally friendly.

During all its activities, seele pays particular attention to the emission of pollutants and to reducing noise, dust, dirt and toxic treatments. We take the most stringent precautions to avoid health hazards and to ensure that the impact on the environment is minimised.

seele will continue to develop an environmentally aware approach within the company, recognising that sound management of energy and resources can cut costs and create competitive advantages.

10.2 Preventing pollution

Pollution and hazards caused by urban construction projects have become a serious problem. Sources of pollution and hazards from construction sites include dust, harmful gases, noise, bright lights, solid and liquid wastes, ground movements, mess and debris, fallen items, etc.

Air pollution

Construction activities contribute to air pollution through the operation of diesel engines, demolition work, burning, working with toxic materials, etc. All construction sites generate high levels of dust and this can spread over large areas over a long period of time, invisible to the naked eye.

Polluted air may penetrate deep into the lungs and cause a wide range of health problems, including respiratory diseases, asthma, bronchitis, even cancer.

Water pollution

Sources of water pollution on building sites include: diesel and oil, paints, solvents, cleaners and other harmful chemicals, construction debris and dirt.

Noise pollution

Construction sites produce a lot of noise, mainly from vehicles, heavy equipment and machinery, but also from people shouting and radios turned up too loud. Excessive noise is not only annoying and distracting, but can lead to hearing loss, high blood pressure, disturbed sleep and extreme stress.

Measures to prevent pollution

Good working practices can help to control and prevent pollution. Specific measures can be taken to mitigate certain risks:

- Cover skips and trucks loaded with construction materials
- Use non-toxic paints, solvents and other non-hazardous materials wherever possible.
- Segregate, cover tightly and monitor toxic substances to prevent spills and possible site contamination
- Do not burn materials on site
- Reduce noise pollution by handling materials carefully, using modern, quiet power tools, equipment and generators, using low-impact technologies and erecting wall structures as noise barriers

10.3 Use of hazardous materials

Remember

- Always identify all hazardous substances used
- Always clean all equipment or dispose of it correctly
- Always keep a fire extinguisher within reach when using flammable substances
- Always follow the risk assessment and Material Safety Data Sheets as well as manufacturer's recommendations and guidelines for every activity involving hazardous substances
- Always store hazardous substances according to the manufacturer's instructions and seele's risk assessment
- Always dispose of waste materials according to the manufacturer's instructions
- Always contact your doctor if you start to suffer ill health as a result of using a substance

- Never expect people to know that a substance is hazardous – it may not be obvious
- Never ignore health symptoms, e.g. rashes, allergies, asthma. Some people may be affected more than others
- Never transfer hazardous substances to other containers
- Never rely on personal protective equipment as the only means of control – it is the last line of defense



10.4 Managing site waste

All waste on site should be segregated and disposed of in the correct containers. Familiarise yourself with the disposal procedures on your site and follow them. Help to manage site waste more effectively in order to reduce potential harm to the environment and human health.

11 Protection of the public

11.1 Construction work and the public

Construction sites create risks not only for construction workers, but also for members of the public where the construction work is carried out on a site that is near or adjacent to the property boundary or any public place. Some examples of the hazards are:

- changes to surface levels
- excavations, holes and trenches
- falling material and debris
- machinery and equipment
- dust, vapours or other hazardous substances
- noise
- vibration
- site visitors

The general public must be protected from the hazards associated with construction work that is carried out in a public area or adjacent to such an area.

Precautions

The risks can be reduced in the following ways:

- Wear PPE, including high-visibility clothing
- Identify areas at risk and provide warning signs
- Control access to the work area by physical barriers or warning signs. If tape is used, ensure it does not become a tripping hazard itself
- Work during hours when the public is less likely to be in the area
- Provide clear signs and proper protection at obstructions
- Avoid trailing cables (especially on stairways). Cover or fix any that must cross pedestrian areas
- Provide lighting at night and in dark areas
- Clear away all spillages and obstructions from public routes as soon as possible and clear the area completely before the public is re-admitted

11.2 Traffic management in public areas

Problems

Delivery and other moving site vehicles create several hazards:

- Pedestrians may be struck by vehicles entering or leaving the site
- Site and delivery vehicles may obstruct the pavement, forcing pedestrians into the road where they can be struck by other vehicles
- Vehicles may collide with non-site vehicles while entering or leaving the site
- Unsecured loads or those that have moved during transit may fall off, striking pedestrians or other vehicles
- Unauthorised use of vehicles that are not switched off or locked when the driver is absent
- Space constraints and restrictions may obstruct the public but also the execution of the works

Precautions

It is important to consider access and approaches to the site during the planning stage. Think about the proximity of the public, about traffic and possible busy periods. The risks to pedestrians and drivers of other vehicles can be reduced in several ways:

- Use warning tapes, barriers, cones and a flagman to segregate pedestrians and vehicles
- Avoid crossing traffic flows. Divert site traffic away from pedestrian areas
- Control stocks to make sure you have the right materials at the right times
- Consider providing adequate space on site for unloading vehicles
- Allow sufficient clearance around vehicle-mounted loading/unloading booms
- Give delivery companies advance notice of routes to follow or avoid, and loading/unloading arrangements etc
- Make sure all loads are properly secured
- Secure vehicles and equipment when not in use. If possible, leave them in a secure area overnight and immobilise them; develop a traffic plan when affecting pedestrians or vehicular traffic



Make sure all loads are properly secured!

11.3 Protection of the public – machinery and equipment

Problems

The use of machinery and equipment presents a range of hazards to the public.

Precautions

The risks can be reduced in the following ways:

- Immobilise all equipment outside of working hours
- Remove keys and starting handles and store them in a compound or similar secure area
- Place the forks of fork-lift trucks on the ground at the end of the day
- Avoid driving fork-lift trucks along public roads with the forks raised too high
- Avoid lifting loads across public areas and make sure you use the right equipment for the right task
- Support and chock bowsters/tankers properly to prevent accidental movement
- Remove cartridge guns and cartridges from site, or lock them up at the end of the day, and clear up all used and misfired cartridges at least daily
- Check that all machinery and equipment operatives are fully competent and do not operate tools or equipment they do not know how to use

11.4 Protection of the public – storing and stacking materials

Problems

Stored materials can constitute several hazards:

- Materials may fall from storage areas, scaffolds or other working platforms
- Partly open pallets and badly stored materials can topple
- Certain materials stored horizontally and not secured can be moved by high winds or passing traffic, for example
- Materials stored upright can topple over, e.g. unsupported glass panes propped against a wall
- Persons can fall from storage areas, stacks, etc., which may also be used as a means of gaining access to other dangerous positions
- The public may be struck by materials and equipment or exposed to hazardous substances

Precautions

The risks associated with the storage of materials can be reduced in the following ways:

- Store materials within the site perimeter, preferably in secure compounds or away from the perimeter fencing. The area should be well lit and fully secured to discourage unauthorised entry
- Store pallets on level ground. Remember that the contents of pallets become less stable once the packaging is broken
- Store materials such as plywood horizontally and make sure such materials are firmly secured to prevent them being blown away, especially when they are stored at height
- Prop or secure vertical stacks of materials and materials stacked against walls etc. (e.g. glass crates) to prevent them toppling. Purpose-built storage frames may be appropriate
- Make sure loose materials stored on platforms or other similar areas cannot fall accidentally. Toe-boards and brick guards should be in place. Materials should not be stacked above the height of the brick guards
- Set up warning signs

11.5 Protection of the public – falling objects

Problems

Members of the public have been seriously injured and even killed after being struck by falling or ejected objects.

Precautions

Priority must be given to stopping objects falling in the first place. When you have done what you can to achieve this, you then need to take steps to stop people being struck by any objects that do fall:

- Always plan how materials will be raised and lowered
- Do not throw materials into an uncontrolled area
- Avoid working above a public area
- Ensure there are safe systems in place for operations such as striking formwork, dismantling scaffolds, etc. in order to prevent components and timber falling into public areas, e.g. provide netting to catch small pieces of ejected material
- Protected walkways may be needed in some circumstances, e.g. where objects could fall into pedestrian areas
- Where it is not possible to eliminate the risk of objects falling or being ejected, the area should be fenced off or at least demarcated. Only authorised people should enter and even their access should be controlled to avoid times when there is a risk of them being struck

12 Miscellaneous

12.1 Confined spaces

Every year, a number of people are killed or seriously injured when working in confined spaces in a wide range of industries, from those involving complex machinery to simple storage vessels. Those killed include not only people working in the confined space but those who try to rescue them without proper training and equipment.

A confined space can be any area of an enclosed nature where there is a risk of death or serious injury from hazardous substances or dangerous conditions (e.g. lack of oxygen). It can also be an area with limited means of access and egress, or an area not designed for continuous occupancy, or an area large enough for a person to enter and fully perform assigned work.

- Avoid entering confined spaces – do not enter a confined space unless you have been properly trained
- Always refer to the risk assessment specific to the task and contact your supervisor prior to commencing works in a confined space



12.2 Working near or over water

Where there is a significant risk of drowning, seele will prepare a method statement detailing measures to prevent accidental entry into the water. This will ensure the following:

- All scaffolds and work platforms (including floating platforms) from which a person can slip or fall must be fitted with guardrails, toe-boards and, where appropriate, brick guards
- Access adjacent to or above water is similarly protected
- Where it is not reasonably practicable to provide adequate edge protection, safety harnesses, usually in conjunction with self-inflating life-jackets, must be worn and secured to a safe anchorage point. It is best practice for safety lines and harnesses to be used in addition to working platforms in case of failure of the platform. Anchor points must be located on the main structure
- Appropriate rescue and emergency equipment and procedures must be in place, e.g. rescue boat, safety nets, lifebuoys and lines, lighting, audible alarms, communications, etc.
- Where rescue boats are used, the vessels should be appropriately maintained and the crew properly trained
- All personnel working over or near water and who are at risk from falling in must wear an appropriate life-jacket or buoyancy aid. Self-inflating life-jackets with lines attached to a secure point are considered to be effective (type III floatation device)

- Throwing lines can be thrown further than lifebuoys and may be more appropriate in many cases, as a backup for other measures
- An operative must be trained in the use of such equipment, which must be regularly checked and serviced, with compressed-air inflation devices being replaced as necessary
- No persons should work alone in areas with a significant risk of drowning in water, silt, etc.
- Illumination must be provided for night-time rescues, e.g. pivoting spotlights at strategic points to assist in locating a person in the water
- The number of persons at work over water should be checked periodically to ensure no one is missing
- Operatives should work in pairs
- Operatives must receive training in emergency procedures

There are numerous byelaws and local requirements that can be applied by, for example, coastguards, port authorities (ports), harbour authorities (coastal works), waterways bodies (canals), local government (inland lakes) and water authorities (reservoirs). Prior to commencing work over or near water, managers should contact these organisations and obtain comprehensive information on relevant byelaws and conditions and comply with these at all times.

12.3 Underground services

Utility services such as water, gas, electricity and telecommunications are commonly installed and routed below ground level (underground/buried services). There are many advantages to be gained by doing this, which include:

- Safety – e.g. to isolate the services from the general public
- Appearance – e.g. to place unsightly pipes, cables and associated items out of view.
- Protection for the services – e.g. from vandalism, or freezing conditions in the case of water pipes

Accidental damage

The risks of accidental damage normally occur after physical contact with a service, as might result if an electric cable is struck by the bucket of a mechanical excavator or a water pipe is punctured with a pickaxe. Other kinds of damage to buried services may occur without excavation having to take place, e.g. as a result of penetrating the ground with a gas sniffing bar or a road pin or from being crushed by the weight of equipment such as the outriggers of mobile cranes.

A service might also become damaged if it moves under its own weight, which can happen if soil is removed from beneath a steel pipe. Services encased in concrete can suffer a similar fate if the ground supporting the heavy concrete is removed or disturbed; the concrete may then move under its own weight and fracture the service within it, resulting in significant risks – especially if the service is an electric cable or a gas pipe.

seele's general advice for achieving safe working near underground services is always to 'PACE' the work, i.e.

P – plan the work before starting,

A – ask for information on the locations of buried services,

C – confirm the exact location of buried services, and

E – ensure that ground compaction tests have been undertaken.

If a service is damaged:

- Stop work instantly
- Report the damage to a line manager (who must then contact the appropriate authority immediately)
- Do not continue work until a person in authority deems the area to be safe and/or confirms that the service has been isolated or repaired

Copyright

The copyright for this handbook is with
seele holding GmbH & Co. KG
Einsteinring 1
86368 Gersthofen
Germany

The illustrations on pages 66, 69, 71, 74, 76, 79, 82 and 85 were supplied by the Lifting Equipment Engineers Association (3 Osprey Court, Kingfisher Way, Hinchingsbrooke Business Park, Huntingdon PE29 6FN, United Kingdom), which also holds the respective copyright.

The illustrations on pages 2, 7, 11, 12, 15, 17, 25, 27, 28, 34, 37, 39, 41, 43, 44, 51, 53, 54, 60, 88, 91, 96, 100, 107, 119, 123, 128, 133, 138, 144 have been produced by Ian D. Marsden for seele.

health & safety manual – personal data

About you

Title:

First (given) name:

Surname (family name):

Gender:

Date of birth:

Primary language:

Home address:

Postcode:

City:

Home phone number:

Mobile number:

E-mail address:

Do you require information in any language other than English?

Yes

No

Experience

Occupation:

Experience in occupation (years):

Experience with seele (years):

Emergency contact

First (given) name:

Surname (family name):

Relationship to you:

Phone number:

Address:

I confirm that I will read and study the contents of this seele health & safety manual.
If I do not understand a section of the seele health and safety manual, I will contact my supervisor or site manager immediately.

Personal protective equipment (PPE)

In support of the seele commitment to health and safety, it is company policy that a minimum requirement for the wearing of PPE is clearly stated for all construction sites.

